

OnGuard System

WARNING

Unsafe use of this machine may cause serious injury or death. Operators and maintenance personnel must read this manual before operating or maintaining this machine. This manual should be kept near the machine for reference and periodically reviewed by all personnel who will come into contact with it.

NOTICE

Komatsu has Operation & Maintenance Manuals written in other languages. If an alternate language manual is necessary, contact your local distributor for availability.

Preface

This Manual is provided as a guide to personnel involved with the operation, maintenance and repair of Komatsu equipment. We recommend that such personnel review and become familiar with the general procedures and information contained within this manual. In addition, we recommend that this manual be kept readily available for reference when repairs or maintenance are necessary.

Read and become familiar with this Manual and any other general safety practices before attempting any procedures.

Due to the complexities of mining equipment and the environment in which it operates, situations may arise which are not directly discussed in detail in this Manual. When such a situation arises, past experience, availability of equipment and common sense play a large part in what steps are to be taken. In addition, a Komatsu service center representative is available to answer your questions and assist you upon request.

Certain equipment, such as equipment requested by a customer or required by applicable law, is not manufactured or specified by Komatsu. Equipment which is neither manufactured by Komatsu nor specified by Komatsu is referred to as "Third Party Equipment". Komatsu shall have no liability for any losses, injuries or damages, whether to person, property, or otherwise, arising from the selection, installation, or use of Third Party Equipment, or any defect in the design, materials or workmanship of Third Party Equipment, whether such losses, injuries or damages arise in tort (including negligence and strict liability), contract, warranty, contribution, indemnity or otherwise. References and referrals to written materials detailing Third Party Equipment ("Third Party Materials") contained herein is provided "as-is" and for informational purposes only. Komatsu shall have no liability for, and expressly disclaims, any warranties, statements, or guarantees made in any Third Party Materials. Third-party trademarks and service marks are the property of their respective owners.

Komatsu reserves the right to continually improve its products and associated documentation. Therefore, physical alterations to Komatsu equipment may not be identified in this Manual. Revisions may be frequently made to this Manual in an effort to ensure that information contained within is current as alterations occur to the equipment. If you find an error or have other feedback regarding this Manual, please contact Product Training and Publications at *Pro.Train.Pub@global.komatsu*.

Copyright

© 2025 Komatsu Ltd. or one of its subsidiaries. All rights reserved. This Manual is protected by United States copyright law and international treaties, and may not be reproduced, distributed, transmitted, displayed, published or broadcast without the prior written permission of Komatsu or one of its affiliates. You may not alter or remove any trademark, copyright or other notice from copies of this Manual. All rights in translations of this Manual remain exclusively with Komatsu or one of its affiliates.

Safety Hazard Indicators



DANGER

Indicates an imminently hazardous situation which, if not avoided, *will* result in death or serious injury. This signal word will be limited to the most extreme situations.



WARNING

Indicates a potentially hazardous situation which, if not avoided, *could* result in death or serious injury.



CAUTION

Indicates a potentially hazardous situation which, if not avoided, *may* result in minor or moderate injury.

CAUTION

A Caution without a safety alert symbol (no triangle and exclamation point) is used to warn of hazards that result only in property damage.

NOTICE

Used to indicate a statement of company policy directly or indirectly related to the safety of personnel or protection of property. This signal word is not associated directly with a hazard or hazardous situation and is not used in place of DANGER, WARNING, or CAUTION.

Table of Contents

Revision Record – MAOG-A-V-MM	7
System Description	9
OnGuard Generic Unit	11
OnGuard User Interface	11
Operating the Controller Display.....	13
OnGuard Active Unit	25
OnGuard TS UI	25
Home Screen	25
Action Menu	28
Operator Menu	32
Admin Menu	34
Web Interface	43
Connecting to the Web Interface	43
Network Connection.....	43
Live Dashboard	44
Live Charts	45
Telemetry – Admin Only.....	48
Edit Configuration – Admin Only.....	54
How to use the Web Interface to Connect OnGuard to a Wi-Fi Network.....	56
Connecting with Ethernet.....	58
Data Types and Measurement Details	63
About.....	63
Components	65
OnGuard Interface Module	65
Sensor Pod	65
How to Replace a Sensor Pod	66
Variable Speed Pressurizer	68
Variable Speed Pressurizer Air Filter Replacement.....	69
Variable Speed Pressurizer Replacement	70
Clean Cab Variable Pressurizer Motor Control.....	71
Maintenance	73
Troubleshooting	75
Controller Display Screen Messages.....	75
Index	79

This Page Intentionally Left Blank

Revision Record – MAOG-A-V-MM

Version	Revision Description	Author	Date and WC Version
0000	Initial release		6/24
0001	Reorganized and updated manual topics to follow new information from the OnGuard TS UI manual provided by MineAir.	AJK	6/25 WC B.1
	Added chapter <i>OnGuard Active Unit</i> on page 25 to add information from the OnGuard TS UI manual provided by MineAir.		
	Updated chapter <i>Web Interface</i> on page 43 with information from the OnGuard TS UI manual provided by MineAir.		
	Added <i>Maintenance</i> on page 73 and <i>Clean Cab Variable Pressurizer Motor Control</i> on page 71.		

This Page Intentionally Left Blank

System Description

Figure 1: Pressurization and OnGuard Monitoring System

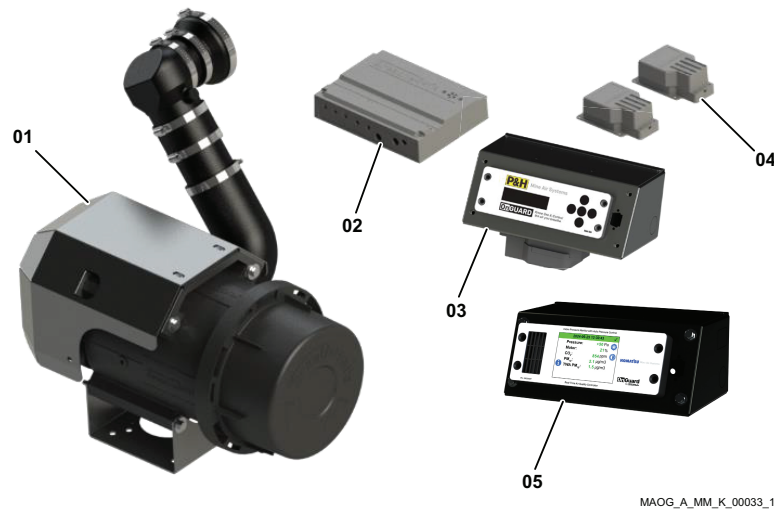

01 - Variable Speed Pressurizer Assembly

02 - OnGuard Interface Module (Main Unit)

03 - OnGuard User Interface (UI)

04 - Breathing Zone and Return Air Sensor Pods

05 - OnGuard User Interface Touch Screen (UI TS)

The Pressurization and OnGuard Monitoring System continuously monitors and records the following:

- Operator Cab pressure
- Operator Cab CO₂ levels from the operator
- Operator Cab dust particulate mass concentration
- Operator Cab dust particulate particle counts
- Operator Cab temperature and humidity
- Pressurizer Motor Speed

OnGuard will arrive primed with a usable factory default configuration. For instance, a kit with multiple sensor zones will be primed to know what accessories should be connected and their assignment. The operator's cabin pressure and CO₂ set points are programmed during commissioning. The configurations that are set can be reverted at any time by an admin from the Web Interface or User Interface. These set points are not adjustable by machine operators.

OnGuard provides real-time updates on the parameters it is monitoring and allows operator and administrator access to execute several different functions and adjust a vast number of settings. Once cabin pressure, CO₂, and dust particulate set points are met, the OnGuard system will slow down the pressurizer motor speed to increase pressurizer filter life and reduce HVAC load. OnGuard continuously monitors the conditions in the cab and compares them to the set points. As filters become clogged, the cabin pressure will decrease and CO₂ levels increase. In return, the motor speed will increase, bringing in more outside air through the pressurizer.

The kit contents and zone assignments are shown on the information sheet provided with the kit. The provided information sheet will contain:

1. A description of parts included in OnGuard kit, their serial numbers, and assignment.

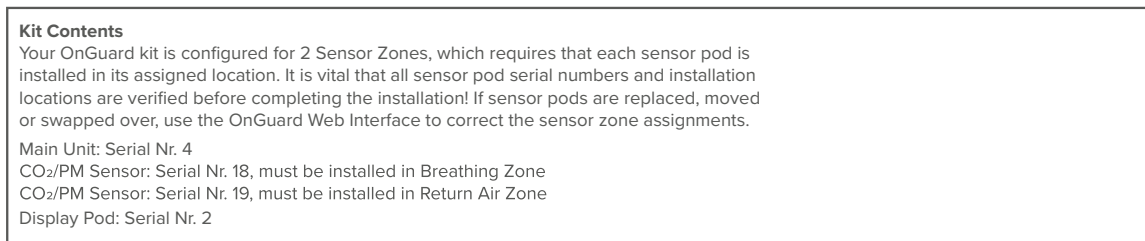
Figure 2: OnGuard Kit Contents

MAOG_A_MM_K_00030_1

2. Admin and operator access credentials necessary for accessing user-specific functionality on the User Interface (UI) and Web Interface.

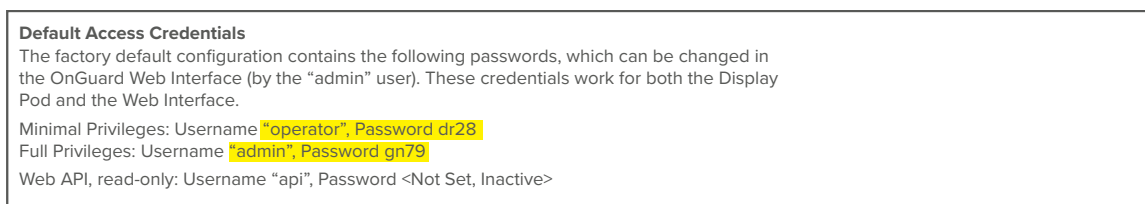
Figure 3: Default Access Credentials

MAOG_A_MM_K_00031_1

3. OnGuard's loaded network configuration.

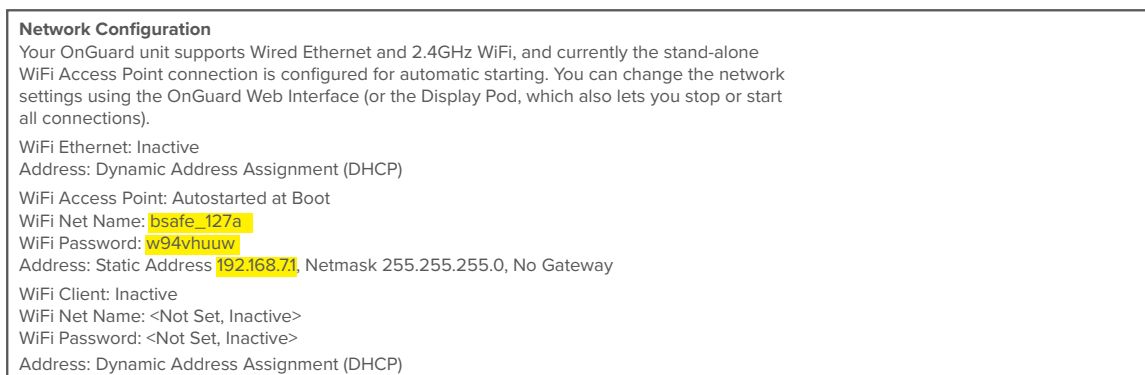
Figure 4: Network Configuration

MAOG_A_MM_K_00032_1

OnGuard Generic Unit

The OnGuard Generic Unit consists of the components in the graphic below:

Figure 5: System Layout

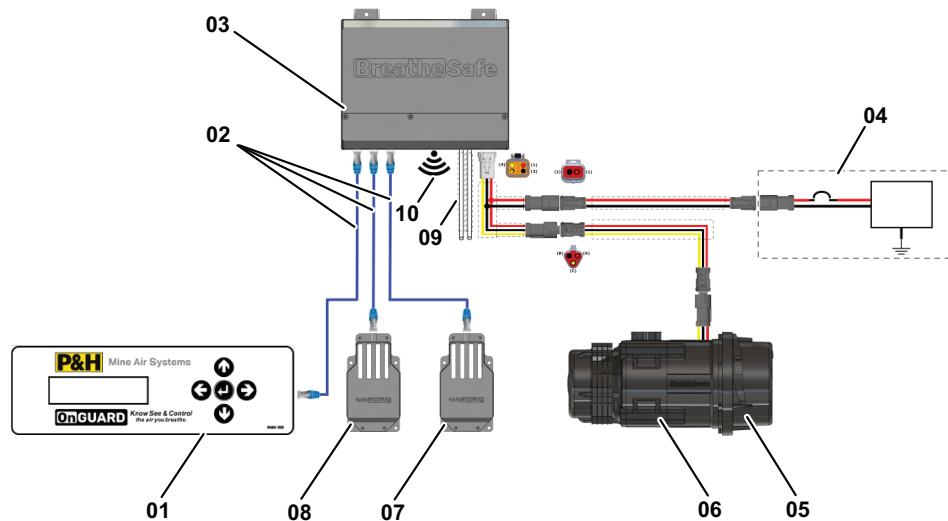

MAOG_A_MM_K_00001_1

01 - OnGuard User Interface (UI)

02 - RJ45 Cables

03 - OnGuard Interface Module

04 - Power Connection (Not provided)

05 - Pressurizer HEPA14 Fresh Air Filter

06 - Variable Speed Pressurizer

07 - Breathing Zone Sensor

08 - Return Air Sensor (Optional)

09 - Pressure Sensor Tubing

10 - Wi-Fi Antenna

OnGuard User Interface

The OnGuard User Interface (UI) normal mode of operation provides a rotating display of the parameters it is monitoring. It will also provide both audible and visual alarms if the conditions in the operator's cabin exceed programmed settings.

Figure 6: OnGuard User Interface



ESGN_C_MA_K_00071_1

During normal operation, the UI will display:

- Cabin pressure (top left)
- Pressurizer motor speed, as a percentage (top right)
- A constant rotating update of date and time, PM10 concentration, PM2.5 concentration, and CO₂ concentration measurements (bottom left)

Figure 7: OnGuard User Interface Rotating Display Example



ESGN_C_MA_K_00021_1

The controller display can change color. The color is dependent on a variety of factors, including pressure and CO₂ level set points, filter cleanliness, loss of cabin pressure, and the duration of the event. There is also a time delay, so the controller does not set the alarm when a door is temporarily opened.

The factory set points are as follows:

Table 1: Factory Set Points

Controller Display Color	Controller Display Color Definition	Pressure Set Point	CO ₂ Set Point
Green	Good	50 Pa	Under 1000 PPM
Orange	Caution	Under 50 Pa	1000 PPM to 2500 PPM
Red	Bad	Under 50 Pa	Over 2500 PPM

Occurrences with the controller display:

- When observing cabin pressure on the controller display, the operator may observe that the cabin pressure will quickly increase or decrease. This will be a normal occurrence on windy days as a pressure reference tube is outside the cab to reference atmospheric pressure.
- CO₂ alarms are not common, and under normal circumstances will only alarm when an operator is breathing directly on the sensor.

Operating the Controller Display

Navigating the controller display is performed exclusively with the 5-button keypad located on the right side of the display.

Figure 8: OnGuard User Interface Controller Display



The up (↑) and down (↓) arrows are used to cycle through:

- Menu Items (functions or configurations)
- Characters/Numbers when editing a parameter

The Left (←) and Right (→) arrows are used to:

- Move between character selection when editing a parameter
- Navigate to X, which will allow the user to exit the current menu/selection when activated

The Enter (↵) button is used to:

- Enter a sub-Menu (for editing configurations)
- Confirm actions (when a parameter is set or to activate a function)

Pressing the enter (↵) button, will either activate the function shown on the screen or, if editing a parameter, will cycle to the next item in the configuration. Pressing enter (↵) at the end of a menu will return the user to the main menu.

The screen brightness can be adjusted using the up (↑) and down (↓) buttons. To increase brightness, press and hold the up button. To decrease brightness, press and hold the down (↓) button. The selected brightness level is stored in the memory and will be used until another adjustment is made.

Action Menu

The action menu allows the user to gain access to the access-restricted menus by entering the administrator or operator pin provided on the Info sheet. See [System Description](#) on page 9.

Additionally, the action menu allows the user to run a max speed test. See [Maximum Speed Test](#) on page 14.

The action menu is opened by holding down the center enter (↵) button or by pressing the up (↑) and down (↓) buttons at the same time.

Access Pin

Once in the action menu, use the up (↑) and down (↓) buttons to navigate to Admin Access and press the enter (↵) button. From here, enter the operator access credentials to access the operation menu or enter the admin access credentials to open the administrator menu.

The pin is entered using the left (←) and right (→) buttons to navigate the character location and the up (↑) and down (↓) buttons to cycle through the list of characters for each position.

How to Gain Access to the Operator and Administrator Menus

Step 1: Press the up (↑) and down (↓) buttons at the same time.

Step 2: Press the down (↓) button until Admin Access appears.

Figure 9: Admin Access Display



ESGN_C_MA_K_00024_1

Step 3: Locate the access credentials (operator or admin).

Access credentials are provided on the Info sheet. See [System Description](#) on page 9.

Step 4: Enter the credentials into the UI.

The up and down buttons are used for setting the character to the current cursor position. The left (←) and right (→) buttons are used for moving the cursor along.

Step 5: Press the enter (↵) button.

Maximum Speed Test

Once in the action menu, use the up (↑) and down (↓) buttons to navigate to Max Speed Test. Begin the test by pressing the enter (↵) button.

This test is primarily intended for commissioning purposes, as it allows the user to determine the maximum pressure that can be achieved in the cabin when the motor is running at 100% speed. Ensure the cabin door and windows are completely closed when running this test.

Figure 10: Maximum Speed Test Display

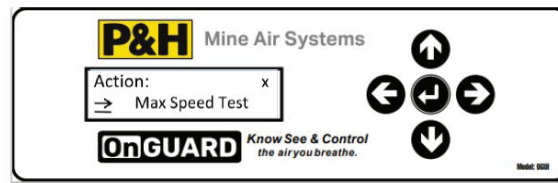

ESGN_C_MA_K_00035_1

Operator Functions: Operation Menu

When authenticated, the operator can navigate through the different options and functions in the operation menu by using the up (↑) and down (↓) buttons.

The operation menu options and functions include:

- Set Date
- Set Time
- Set Time Zone
- Adjust Setpoint
- Calibrate Pressure
- Net Status

If authentication has not been completed, see [How to Gain Access to the Operator and Administrator Menus](#) on page 14.

Setting Date and Time

The Set Date option allows the user to change the date in the DD-MM-YY format.

Figure 11: Set Date Display

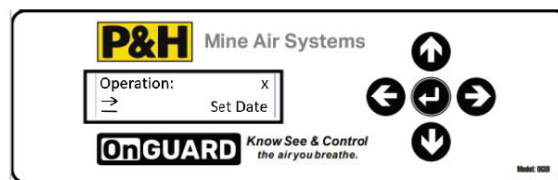

ESGN_C_MA_K_00045_1

The Set Time Zone option will prompt the user to change the time zone using the up (↑) and down (↓) buttons to navigate through time zones, categorized by region.

Figure 12: Set Time Zone Display



ESGN_C_MA_K_00046_1

The Set Time option will allow the user to change the time in the date in the 24-hour "HH-MM-SS" format.

Figure 13: Set Time Display



ESGN_C_MA_K_00047_1

Adjust Setpoint

The Adj. Setpoint option allows the user to change OnGuard’s pressure setpoint. The setpoint defines the pressure that will be maintained by adjusting the pressurizer motor speed.

The default pressure setpoint is 50 Pa.

Figure 14: Adjust Setpoint Display

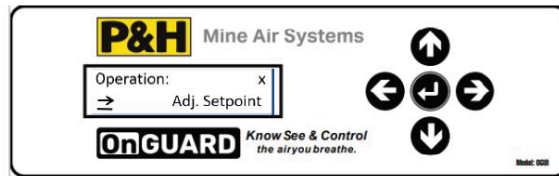

ESGN_C_MA_K_00023_1

Re-Zero: Calibrate the Pressure Sensor

NOTICE

Make sure to have cabin doors and windows open while completing this procedure.

Activating the Calibrate Pressure function will re-zero the pressure sensor to adjust for sensor drift over time and other factors that may have affected its zero point. It is critically important that the cabin door/windows are open when this function is activated, because finding the sensor offset requires the inside and outside pressure to be the same. Once complete, the pressure sensor will be recalibrated and will show roughly 0 Pa when the doors/windows are open.

Figure 15: Calibrate Pressure Display

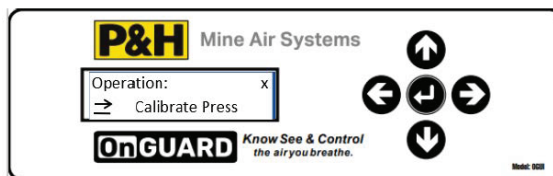

ESGN_C_MA_K_00044_1

Network Status

The Net Status menu allows the operator to view which of the network interfaces are connected and their configuration.

Figure 16: Net Status Menu Display



ESGN_C_MA_K_00039_1

To view the next item in the menu, press the enter (↵) button.

- Wi-Fi Embedded Access Point (AP) network name, password, and IP address (if Wi-Fi is supported).

Figure 17: Wi-Fi AP Network Display

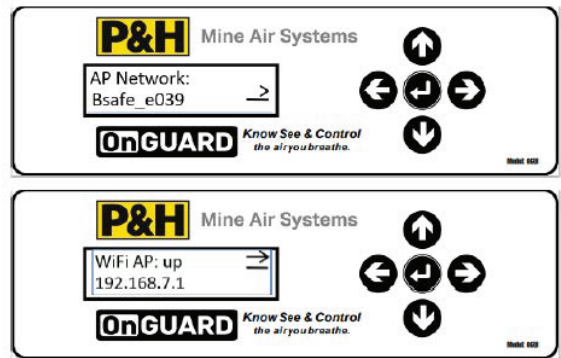

ESGN_C_MA_K_00055_1

- Wi-Fi network name and assigned IP address (if connected to Wi-Fi network).

Figure 18: Wi-Fi Network Name Display

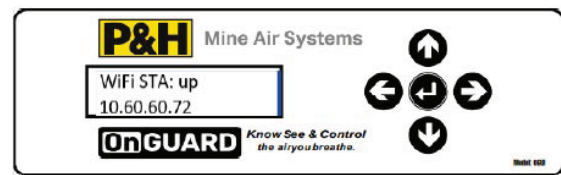

ESGN_C_MA_K_00048_1

- Ethernet IP address assigned to the machine (if connected to a wired ethernet network).

Figure 19: Ethernet IP Address Display

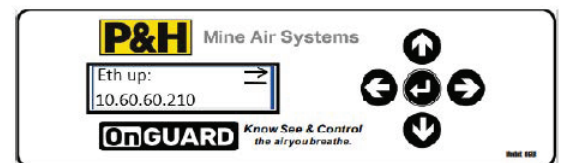

ESGN_C_MA_K_00033_1

Administrator Functions: Admin Menu

When authenticated, the admin can navigate through the different options and functions in the operation menu by using the up (↑) and down (↓) buttons.

The admin menu options and functions include:

- Network Configuration
- AutoTune
- Alert Configuration
- Buzzer Configuration
- Access Operation Menu options and features
- Factory Reset

If authentication has not been completed, see [How to Gain Access to the Operator and Administrator Menus](#) on page 14.

Network Configuration

The Net Config menu allows the administrator to view which of the network interfaces are connected and their configuration.

The administrator can change:

- OnGuard's network configuration.

Figure 20: Network Configuration Menu Display

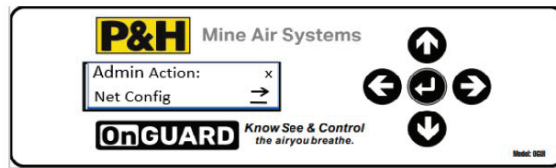

ESGN_C_MA_K_00036_1

- Edit Wi-Fi Embedded Access Point (AP) network name and password.

Figure 21: Wi-Fi AP Network Name Display

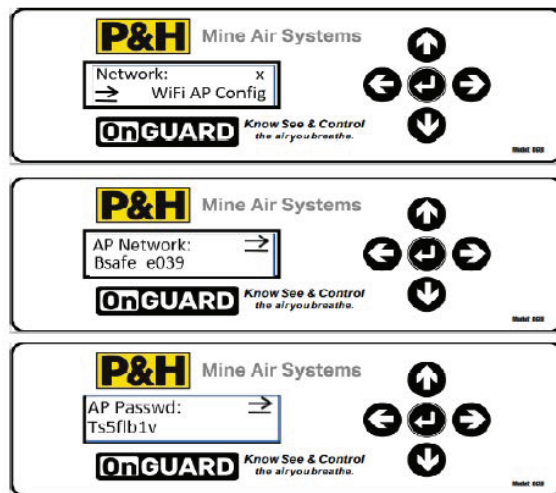

ESGN_C_MA_K_00060_1

- Edit credentials for the Wi-Fi network OnGuard attempts to join on start-up.

Figure 22: Edit Wi-Fi Network Credentials Display

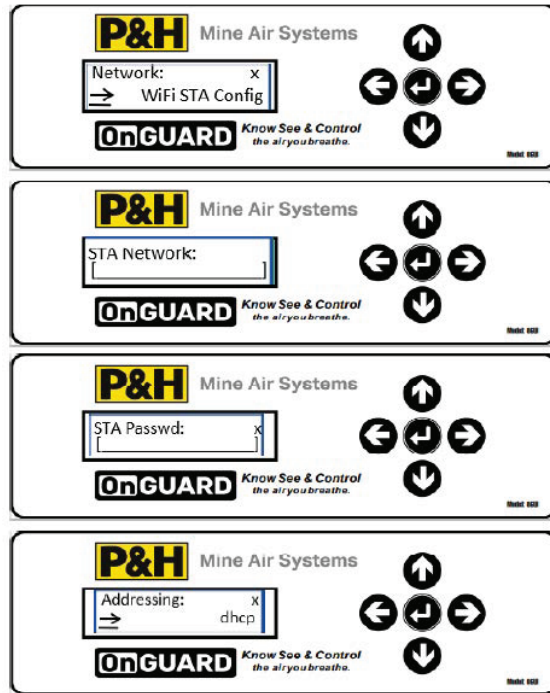

ESGN_C_MA_K_00061_1

- Disable or enable an automatic start at boot for each supported network connection type.

Figure 23: Network Auto Start Display

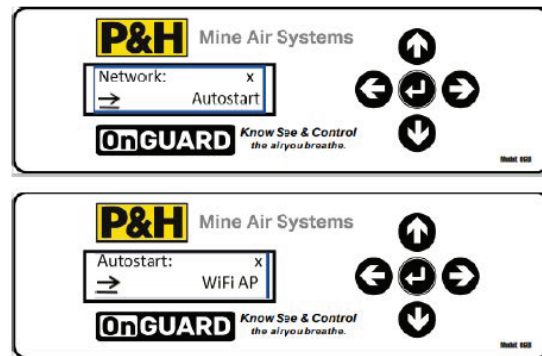

ESGN_C_MA_K_00056_1

- Start all network connections.
 - If the machine's configuration has a network type deactivated, an administrator can activate it from the UI by using the Start function.
 - This function can be used to command OnGuard to re-attempt to connect to a configured Wi-Fi network if the network failed to connect previously.

Figure 24: Start the Network Display

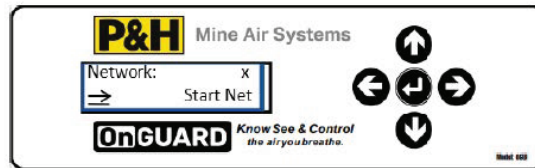

ESGN_C_MA_K_00037_1

- Shutdown all currently active network connections.

Figure 25: Stop the Network Display



ESGN_C_MA_K_00038_1

AutoTune

NOTICE

Do not use the AutoTune feature unless instructed by Komatsu Product Support.

NOTICE

It is critically important that the cabin door and windows are fully closed for the entire duration of the 'AutoTune' operation.

AutoTune is an advanced feature that will only need to be used in special circumstances.

OnGuard uses a proportional integral derivative (PID) control loop to adjust the motor speed to reach and maintain the setpoint pressure. This allows OnGuard to be extremely reactive to pressure changes. The PID control loop's effectiveness is dependent on the cabin size, leakage, and various other parameters.

If the motor adjustment is not working properly (for example, if the pressure and motor speeds fluctuate all the time), then using the AutoTune function may be used to optimize the PID control loop. The AutoTune function will run a pressure test to determine a relationship between speed and pressure. It will then produce a number of oscillation cycles to record the dynamic behavior of the control loop and adjust the control parameters for your specific situation.

Figure 26: AutoTune Display



ESGN_C_MA_K_00057_1

Pressure Test

The Pressure Test function is used to determine if the cabin sealing is adequate. The motor is set to the minimum speed and stepped up periodically until either the test pressure is reached, or until the motor reaches full speed. If the minimum pressure percentage is not reached, a test failure alert is raised.

By default, the pressure test will attempt to reach 250 Pa.

This test will also run on every OnGuard startup.

Figure 27: Pressure Test Display

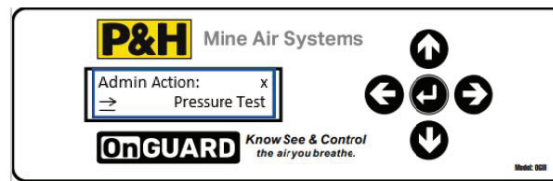

ESGN_C_MA_K_00043_1

Low and High Priority Alerts

The LowPr. Alerts and HighPr. Alerts functions allow the user to adjust the buzzer volume and choose a buzzer type for each alert type. When a user enters one of the menus, the currently selected buzzer sound is played at the currently selected volume.

Figure 28: Low and High Priority Alerts Display



ESGN_C_MA_K_00077_1

Buzzer Adjustments

The Buzzer Volume allows the user to adjust the buzzer volume from 1 to 16, 16 being the highest. The user can also disable the buzzer completely by setting the volume to 0.

Figure 29: Buzzer Volume Display

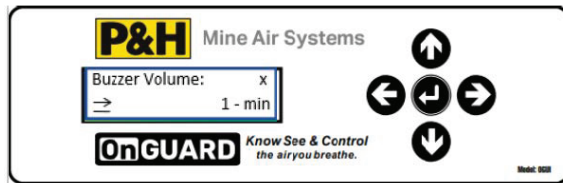

ESGN_C_MA_K_00028_1

The Buzzer Type allows the user to select the sound that will play for the Alert type selected. The buzzer type can only be adjusted if the buzzer has been enabled (volume 1 or above).

Figure 30: Buzzer Type Display

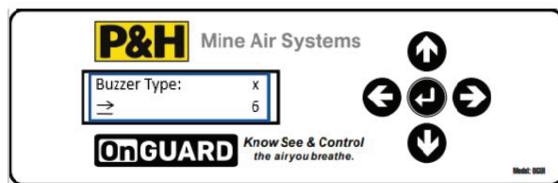

ESGN_C_MA_K_00027_1

Operator Menu Access as an Administrator

Activating Operator Menu will give the admin user access to the operation menu. This will include all of the operator functions. See [Operator Functions: Operation Menu](#) on page 15.

Figure 31: Administrator Operator Menu Access Display



ESGN_C_MA_K_00025_1

Factory Reset

NOTICE

This function will ask the user to confirm their choice before activating, as all recorded data and configuration adjustments are deleted and lost when performing a factory reset.

Activating Factory Reset will restore the OnGuard's configuration to the factory defaults.

Figure 32: Factory Reset Display



ESGN_C_MA_K_00034_1

This Page Intentionally Left Blank

OnGuard Active Unit

The OnGuard Active Unit consists of the components in the graphic below:

Figure 33: Unit Layout

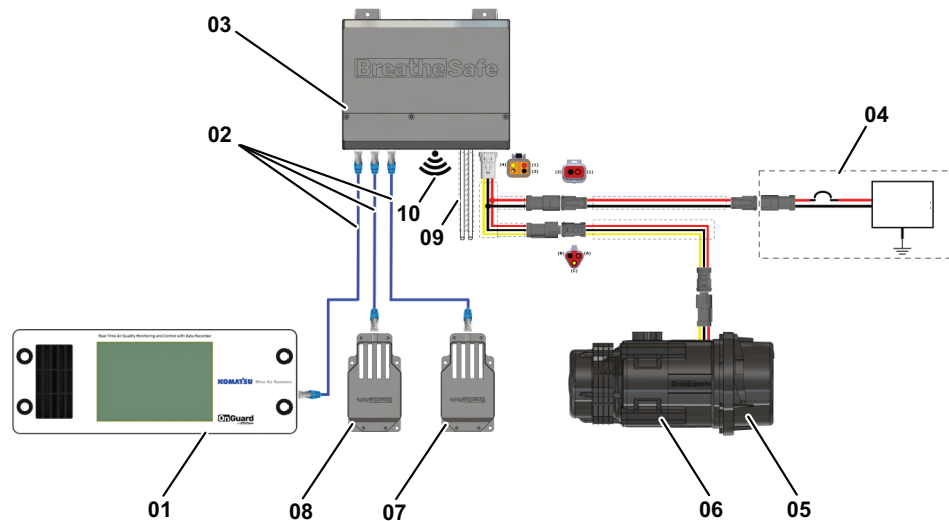

MAOG_A_MM_K_00001_2

01 - OnGuard User Interface Touch Screen (UI TS)

02 - RJ45 Cables

03 - OnGuard Interface Module

04 - Power Connection (Not provided)

05 - Pressurizer HEPA14 Fresh Air Filter

06 - Variable Speed Pressurizer

07 - Breathing Zone Sensor

08 - Return Air Sensor (Optional)

09 - Pressure Sensor Tubing

10 - Wi-Fi Antenna

OnGuard TS UI

Home Screen

The UI TS home screen displays sensor telemetry and control parameters. To apply configuration changes, see [Action Menu](#) on page 28.

During normal operation, the UI will display:

1. Cabin pressure (Pa)
2. Pressurizer motor speed (%)
3. Cabin CO₂ concentration (PPM)
4. Cabin particulate matter (10 micron or less) mass concentration ($\mu\text{g}/\text{m}^3$)
5. Time weighted average of the cabin PM10 mass concentration ($\mu\text{g}/\text{m}^3$)

Figure 34: Home Screen

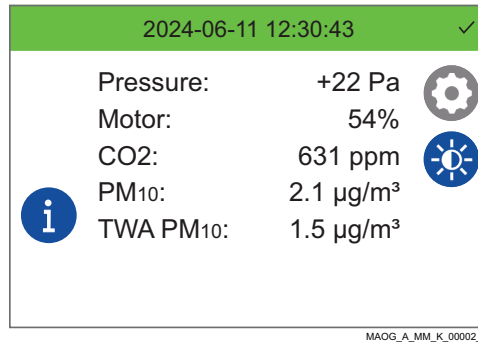

Alerts

While on the home screen, the UI TS will sound audio and show visual alarms to alert users of any events and exceedances that are detected by the monitoring system. The alarm can be muted by pressing the mute button.

A label for the most critical alert will appear at the bottom of the screen. These alerts will be color coded according to the severity of alert. Current alert details can be viewed by pressing the alert label.

Alert details are stored in the alert history located in the action menu, and can be configured through the web interface. For additional details, see [Alert History](#) on page 31. For instruction to access alert history, see [Action Menu](#) on page 28.

Figure 35: Alert Example

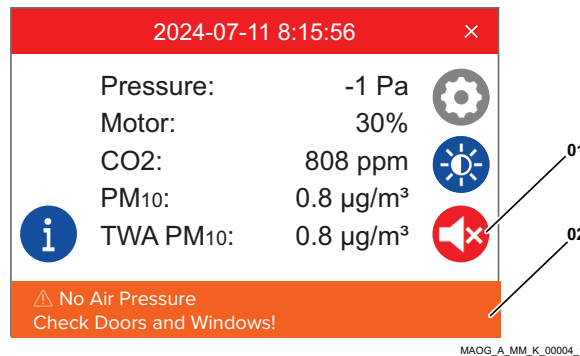

01 - Mute Button

02 - Alert Label

Figure 36: Current Alerts

Current Alerts	
Alert	since
No Air Pressure Check Doors and Windows!	08:12:40
Config incomplete! Set Vehicle ID, SerNr or Tag	07:57:52

Brightness

The screen brightness menu can be accessed by pressing the brightness button on the home screen. Use the slide bar or the + and – buttons to increase and decrease the screen brightness.

Figure 37: Screen Brightness Menu

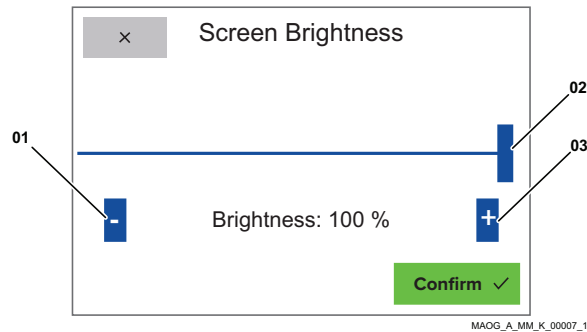

01 - - Button

02 - Slide Bar

03 - + Button

Dashboard

The dashboard screen displays full sensor information, providing a more detailed telemetry than the default display. To access the dashboard screen, press the information button on the home screen.

The dashboard screen will display:

- Cabin pressure (Pa)
- Pressurizer motor speed (%)
- Cabin CO₂ concentration (PPM)
- Cabin particulate matter (10 micron or less) mass concentration (µg/m³)
- Cabin particulate matter (2.5 micron or less) mass concentration (µg/m³)
- Time weighted average of the cabin PM10 mass concentration (µg/m³)
- Temperature (°C)
- Relative Humidity (%)

Figure 38: Home Screen

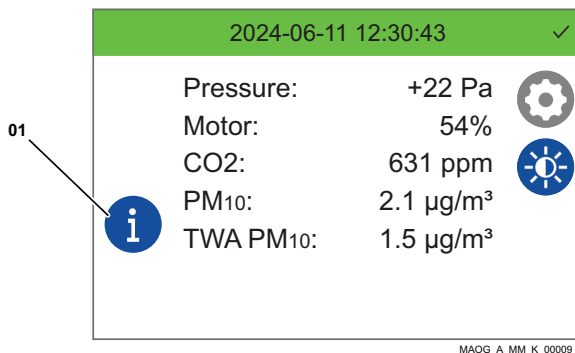

01 - Information Button

Figure 39: Dashboard Screen

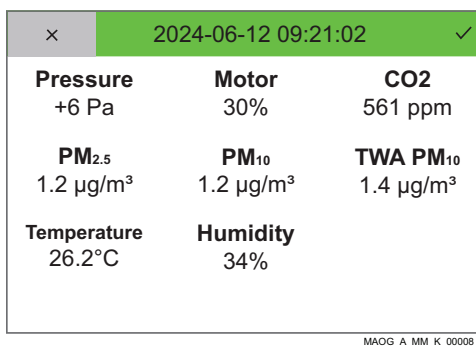

Action Menu

The action menu allows the user to gain access to the access-restricted menus by entering the administrator or operator pin.

Additionally, the action menu gives the user the options to:

- View serial numbers
- View complete alert history
- Perform a Full-Speed Test
- Enter Audit Mode
- Access operator/admin menus
- Start/End shift for TWA

Figure 40: Action Menu

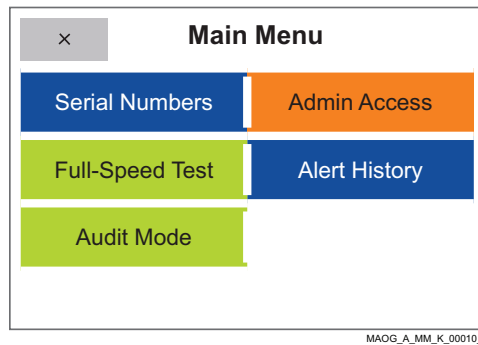

Access Operator and Admin Menus

Before You Begin

The Info sheet must be obtained in order to access the operator or admin menus. See [System Description](#) on page 9.

These instructions outline how to access the operator or admin menus. For specific details about the admin menu, see [Admin Menu](#) on page 34. For specific details about the operator menu, see [Operator Menu](#) on page 32.

Step 1: Turn on OnGuard UI TS.

Step 2: Press the gear button.

Figure 41: Home Screen

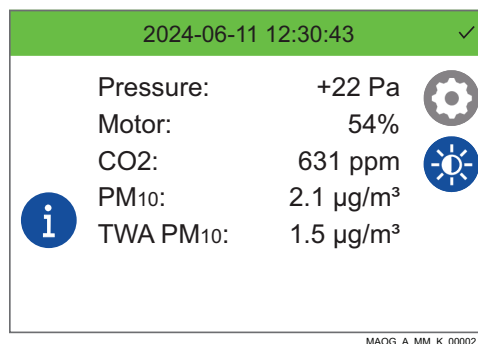

Step 3: Press the Admin Access button.

Figure 42: Action Menu

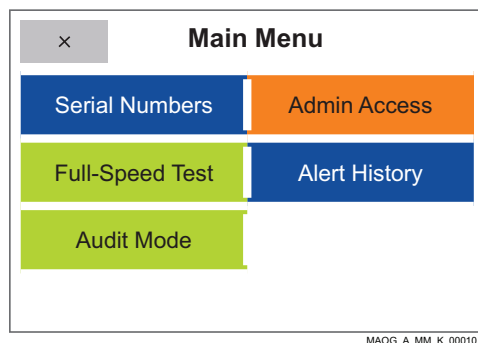

- Step 4:** Select the credential level.
Use the < and > buttons to switch between admin and operator.

Figure 43: Admin Access

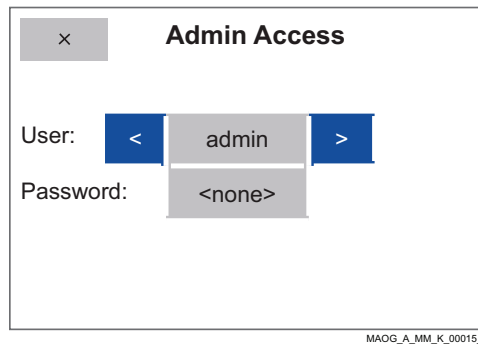

- Step 5:** Enter the password based on the credential level.
Press the enter button to confirm the password.

Figure 44: Enter Password

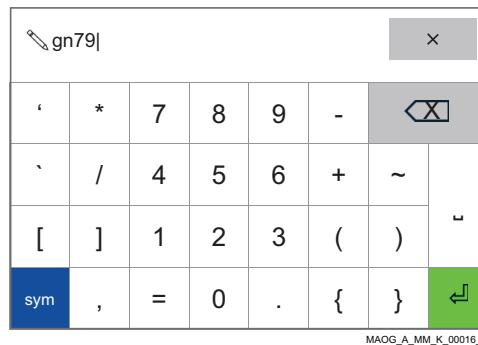

- Step 6:** Press the confirm button to log in.

Figure 45: Press Confirm Button

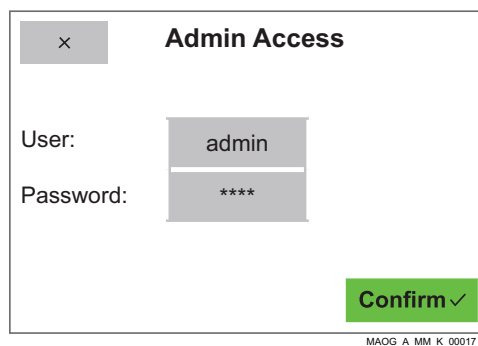

Full Speed Test

The full speed test allows the user to determine the maximum pressure that can be achieved in the cabin when the motor is running at 100% speed. This test is primarily intended for commissioning purposes.

Before running the full speed test, ensure that the cabin windows and doors are fully sealed. A label will appear at the bottom of the home screen when the full speed test is in progress. The test can be disabled by pressing the stop button.

Figure 46: Full Speed Test

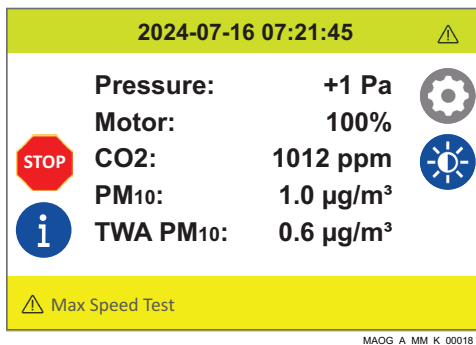

MAOG_A_MM_K_00018_1

Alert History

The alert history page displays ongoing alerts and alerts that have occurred in the past including their end date and time. Additional alert details can be viewed by pressing on the alert. See [Alerts](#) on page 26.

Figure 47: Alert History

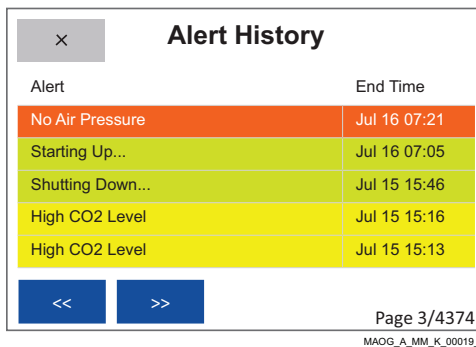

MAOG_A_MM_K_00019_1

Figure 48: Alert Details

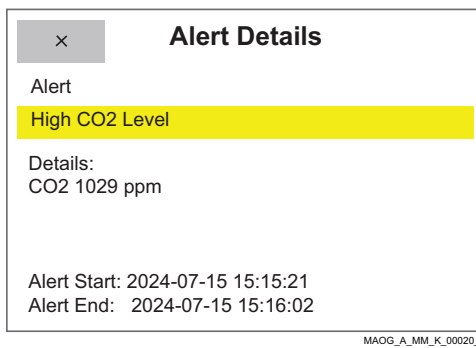

MAOG_A_MM_K_00020_1

Operator Menu

When authenticated as an operator, the user can:

- Adjust the pressure setpoint
- Recalibrate the pressure sensor
- View the network status

Figure 49: Operator Menu

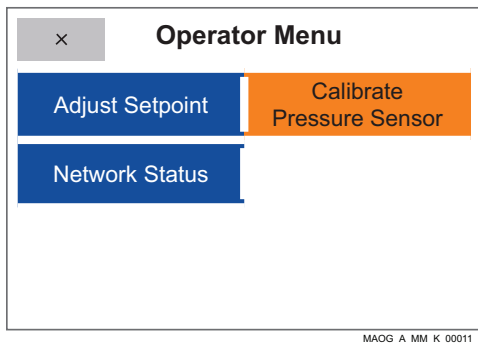

To access the operator menu, see [Access Operator and Admin Menus](#) on page 29.

Adjust Setpoint

The adjust setpoint menu allows the user to change the OnGuard's pressure setpoint. The setpoint defines the pressure that will be maintained by adjusting the pressurizer motor speed. The default value for this is 50 Pa.

Use the + and – buttons to the desired pressure setpoint.

Figure 50: Adjust Setpoint

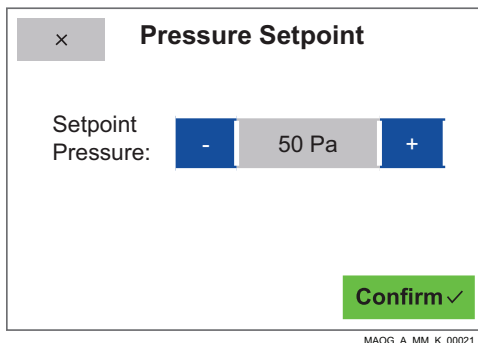

Calibrate Pressure Sensor

Activating the calibrate pressure sensor function will re-zero the pressure sensor. Calibration may be necessary to account for sensor drift over time or due to other factors that may have affected its zero point. It is critically important that the cabin door and windows are open when this function is activated because finding the sensor offset requires the inside and outside pressure to be the same. Once completed, the pressure sensor will be re-calibrated and should show roughly 0 Pa when the doors and windows are open.

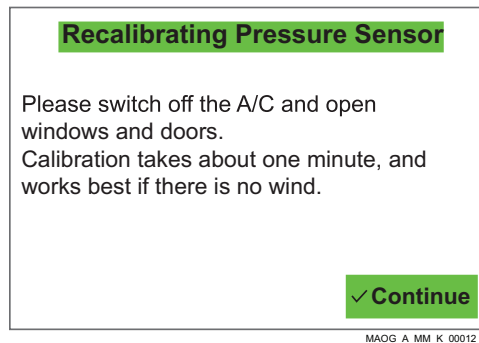
Figure 51: Calibrate Pressure Sensor

Network Status

The network status menu allows the user to view which of the OnGuard's network interfaces are connected along with their configuration.

This includes:

- Wi-Fi Access Point network name
 - Name
 - Password
 - IP Address (If Wi-Fi is supported)
- Wi-Fi network
 - Name
 - Password
 - IP Address (If Wi-Fi client is active)
- Wired Ethernet network
 - Status
 - IP Address (If ethernet is active)

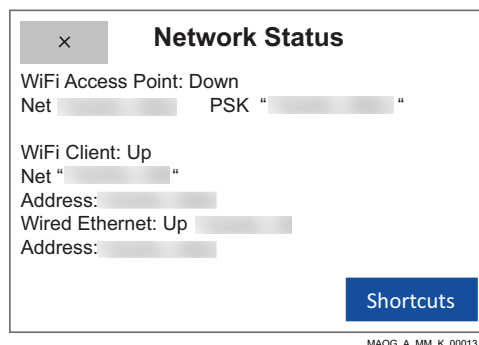
Figure 52: Network Status

The shortcuts button will present the QR codes of the active networks and their IP addresses are displayed. To cycle through the QR codes, press the button beside *For*.

Figure 53: Network Shortcuts

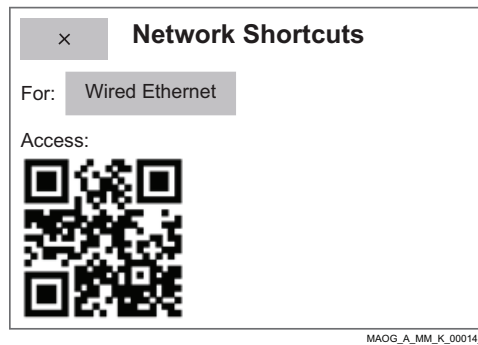

Admin Menu

When authenticated as admin, the user can:

- Set date and time
- Access network configurations
- Run Autotune
- Run a Pressure Test
- Configure the UI's alert options
- Access the operator menu
- Reset the OnGuard unit to factory default

Figure 54: Admin Menu

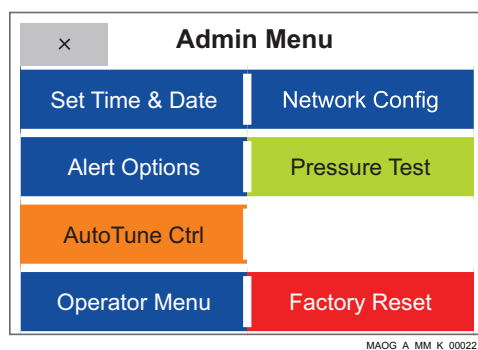

Set Time and Date

The set time and date function allows the user to choose a time zone based on country and city as well as make further configurations to the date and time.

The OnGuard system will not overwrite already recorded data under any circumstances. If the time is adjusted backwards to a time where data has already been recorded, no new data will be recorded until the newly set time exceeds the timestamp of the newest record already in the database. For example, if you rewind the clock by one week, no new data will be recorded for one week.

Figure 55: Set Date and Time

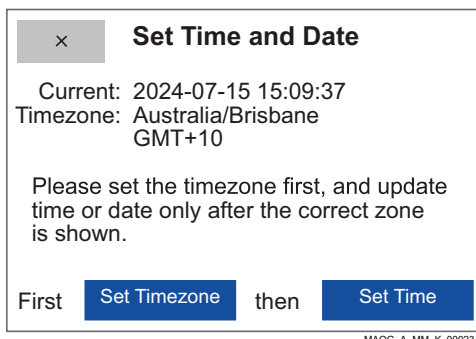

AutoTune Control

NOTICE

Do not use the AutoTune feature unless instructed by Komatsu Product Support.

NOTICE

It is critically important that the cabin door and windows are fully closed for the entire duration of the AutoTune operation.

AutoTune is an advanced feature that will only need to be used in special circumstances.

The OnGuard uses a proportional integral derivative (PID) control loop to adjust the motor speed to reach and maintain the setpoint pressure. This allows the OnGuard to be extremely reactive to pressure changes. The PID control loop's effectiveness is dependent on the cabin size, leakage, and other parameters.

If the OnGuard's motor adjustment is not working properly (for example, if the pressure and motor speeds fluctuate all the time), then using the AutoTune function may be used to optimise the PID control loop. The AutoTune function will run a pressure test to determine a relationship between speed and pressure. It will then produce a number of oscillation cycles to record the dynamic behavior of the control loop and adjust the control parameters for your specific situation.

Figure 56: AutoTune Control

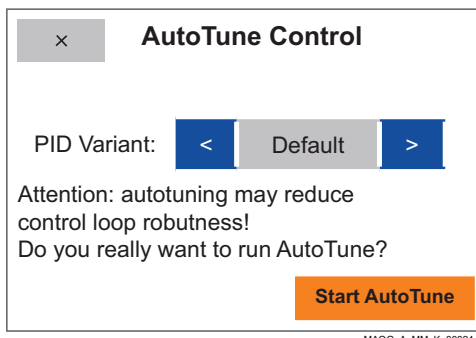

Network Config

The Network Config menu allows the user to view which of OnGuard's network interfaces are connected and their configuration. The user can also change OnGuard's network configuration from this menu.

Step 1: Turn on OnGuard UI TS.

Step 2: Press the gear button.

Figure 57: Home Screen

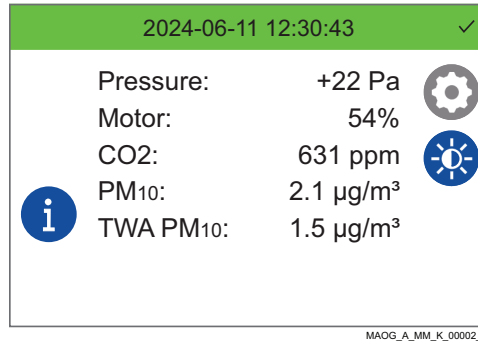

Step 3: Press the Admin Access button.

Figure 58: Action Menu

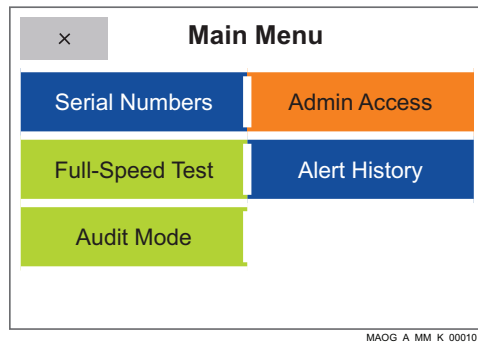

Step 4: Login as an admin.

See [Access Operator and Admin Menus](#) on page 29.

Step 5: Press the Network Config button.

Figure 59: Admin Menu

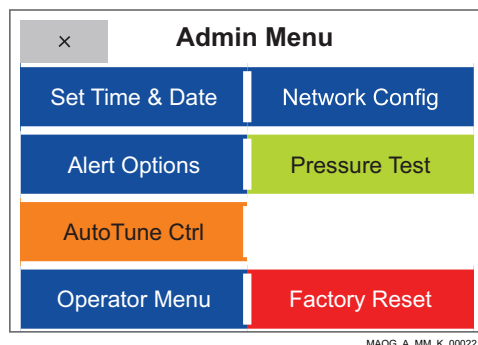

Step 6: Press the gray button next to *Interface* to select a network interface.

See [Figure 61](#) on page 37.

The network interface choices are:

- Wi-Fi Access Point
- Wi-Fi Client
- Wired Ethernet

Step 7: Press the gray button next to *At Startup* to disable/enable automatic start at boot.

See [Figure 61](#) on page 37.

Step 8: Press the blue button to make changes to the selected network interface.

See [Figure 61](#) on page 37.

Step 9: Press the confirm button.

When changes are made, the blue button will change to a green confirm button.

Any changes that are made to a network interface will not be saved unless the changes are confirmed.

Figure 60: Network Interface Changes

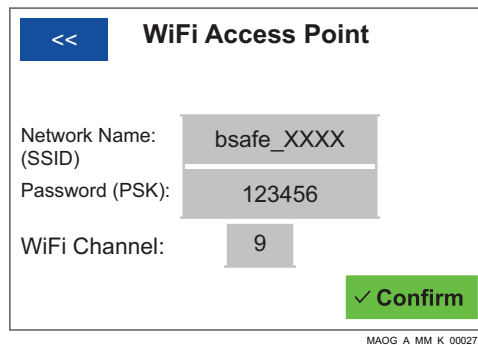

If needed, the Start Now or Stop Now function can be used to cause OnGuard to restart the connection to the Wi-Fi client or stop the network connection.

Figure 61: Network Settings

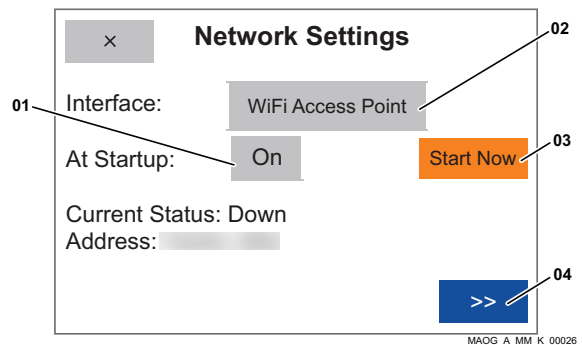

01 - Select Interface Button

03 - Start/Stop Now Button

04 - Network Interface Changes Button

02 - Select Automatic Start on Boot Button

Wi-Fi Client and Wired Ethernet interface choices can be interchanged between Static and Automatic (DHCP) addressing. If Static addressing is selected, the user will be able to edit the IP Address/Mask, Gateway, and DNS server on the network interface changes screen. See [Figure 61](#) on page 37.

Press on the gray button next to *Addressing* to toggle through Static and Automatic (DHCP) addressing.

Figure 62: Addressing Changes

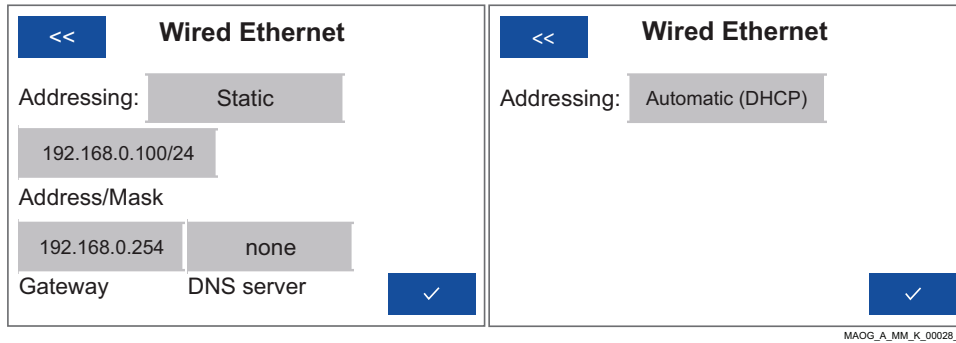

Pressure Test

The pressure test function is used to determine if the cabin sealing is adequate. The motor is set to the minimum speed and stepped up periodically until either the test pressure is reached or until the motor reaches full speed. If the minimum pressure percentage is not reached, a test failure alert is raised.

By default, the pressure test will attempt to reach 250 Pa. This test will also run on every OnGuard startup.

Figure 63: Admin Menu

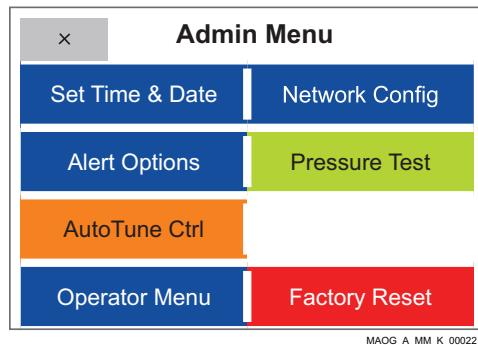

Alert Options

The alert options menu allows the user to adjust the buzzer volume and type for low and high priority alerts.

The type of sound can be changed for each alert by using the type button. The volume can be adjusted by pressing the volume button for each alert.

To test the alert, the selected buzzer type and volume can be played and muted by pressing the alert test button.

Figure 64: Alert Options

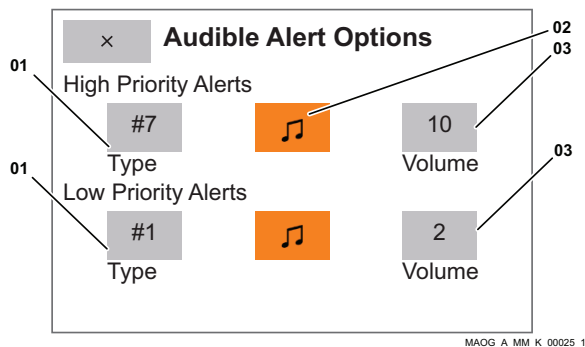

01 - Type Button

02 - Alert Test Button

03 - Volume Button

Factory Reset

CAUTION

Make sure this action needs to take place. Once the reset button is pressed, all configuration adjustments and data will be lost.

Activating the factory reset function will wipe all recorded data and restore the OnGuard's configuration to the factory defaults.

Step 1: Turn on OnGuard UI TS.

Step 2: Press the gear button.

Figure 65: Home Screen

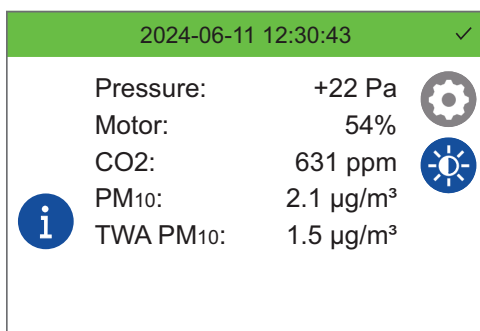

Step 3: Press the Admin Access button.

Figure 66: Action Menu

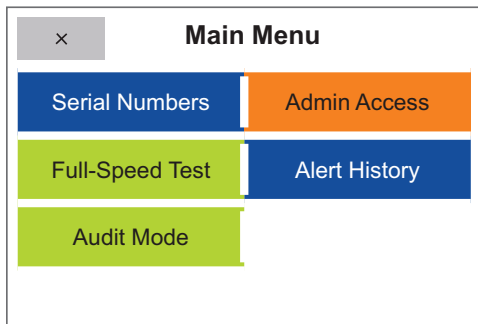

MAOG_A_MM_K_00010_1

Step 4: Log in as an admin.

See [Access Operator and Admin Menus](#) on page 29.

Step 5: Press the Factory Reset button.

Figure 67: Admin Menu

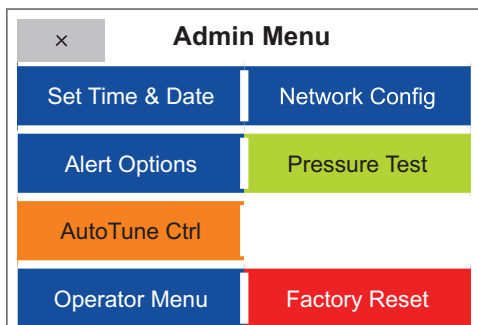

MAOG_A_MM_K_00022_1

Step 6: Use the toggle buttons to select choice.

See [Figure 68](#) on page 41.

Step 7: Press the Reset button.

Figure 68: Factory Reset

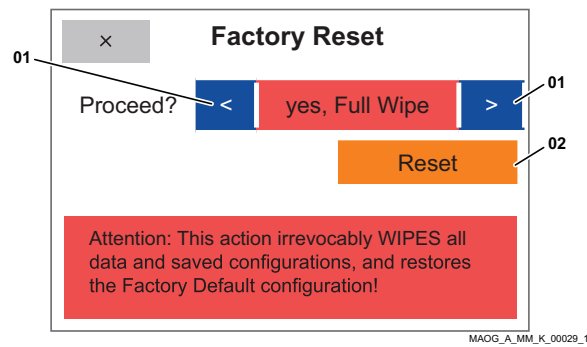

01 - Toggle Buttons

02 - Reset Button

This Page Intentionally Left Blank

Web Interface

The Web Interface allows users to graphically view and download data, view the live status of the monitored cabin conditions, and adjust the unit's configuration settings. The Web Interface exposes the same settings as the UI and allows much more extensive configuration of the OnGuard unit.

Access to the Web Interface will only be granted to a client who has provided a valid username and password. The credentials for accessing the web interface can be found on the Info sheet. See [System Description](#) on page 9.

When authenticated as operator, the client will only be able to access a limited amount of OnGuard's telemetry. Specifically, the operator can only access data charts from the last seven days and view the unit's current status.

Figure 69: Operator Access on Web Interface

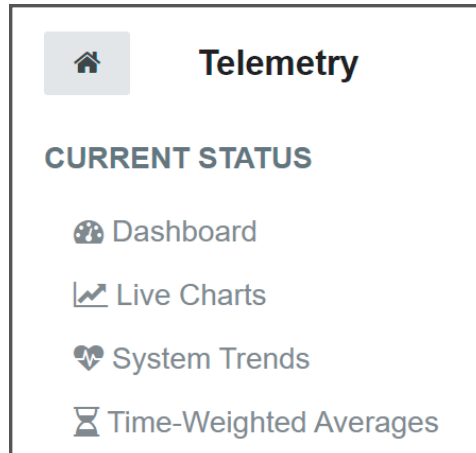

MAOG_A_MM_K_00039_1

When authenticated as admin, the client will be able to:

- Edit the OnGuard unit's configuration.
- Restore OnGuard to previous configurations.
- View the unit's status on the dashboard.
- View charts of all recorded data without time restrictions.
- Download any of the unit's recorded data.

See [Telemetry – Admin Only](#) on page 48 for more information about admin options.

Connecting to the Web Interface

Network Connection

The Web Interface is accessed via a network connection and works with any normal kind of web browser.

OnGuard supports 3 types of network connections:

1. Wired Ethernet
2. 2.4GHz Wi-Fi
3. A stand-alone Wi-Fi Access Point (AP)

Refer to the OnGuard Network Description document for how to connect to OnGuard and configure its network settings.

How to Access the Web Interface using the Wi-Fi Access Point

Before You Begin

The Info sheet must be obtained for details about the Wi-Fi Access Point and for access credentials. See [System Description](#) on page 9.

A 2.4 GHz Wi-Fi capable device will be needed to access the Web Interface.

To access the Web Interface using the Wi-Fi Access Point (AP):

Step 1: Open a web browser.

Step 2: Connect the device to the Wi-Fi network being hosted by OnGuard.

This information can also be found in the admin menu of the OnGuard UI. See [Network Configuration](#) on page 18. For the OnGuard UI TS, see [Network Config](#) on page 36.

Step 3: Enter the IP address 192.168.7.1.

The IP address is the same for all OnGuard kits.

Step 4: Enter the admin or operator username and password.

Figure 70: Wi-Fi Access Point Login Display

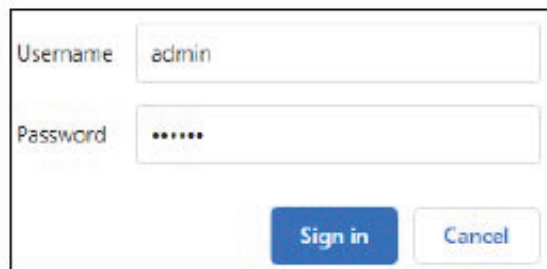

The image shows a login form for a Wi-Fi Access Point. It contains two input fields: 'Username' with the value 'admin' and 'Password' with six asterisks. Below the fields are two buttons: 'Sign in' (blue) and 'Cancel' (white with blue border).

ESGN_C_MA_K_00049_1

Live Dashboard

The dashboard displays the live status of all key parameters that OnGuard is monitoring. Access this feature by clicking on Dashboard under the Current Status heading, which is located on the Web Interface home page. See [Figure 72](#) on page 45.

This interface allows the user to check the state of the unit and check the state of the environment. It will also alert the user if any thresholds are exceeded or of any system faults. The dashboard uses a traffic light system to indicate the status of each parameter.

- Green: Indicates the parameter is within the defined thresholds
- Amber: Indicates the parameter is trending towards an alert
- Red: Indicates an active alert

Warnings and Alerts (amber and red) will usually be displayed with a brief message that describes the cause of the warning.

Figure 71: Dashboard Display

<p>✓ Controller State</p> <p>Normal</p>	<p>✓ Pressure</p> <p>33.1 Pa</p>	<p>✓ Pressuriser Motor</p> <p>18.4%</p>	<p>✓ Last Pressure Test</p> <p>Max 320.4 Pa Motor 65.0%</p> <p>2022-02-23 07:53:20</p>
<p>✓ Inside zone PM_{0.5}</p> <p>0 #/m³</p>	<p>✓ Inside zone PM₁</p> <p>0.0 µg/m³ 0 #/m³</p>	<p>✓ Inside zone PM_{2.5}</p> <p>0.0 µg/m³ 0 #/m³</p>	<p>✓ Inside zone PM₄</p> <p>0.0 µg/m³ 0 #/m³</p>
<p>✓ Inside zone PM₁₀</p> <p>0.0 µg/m³ 0 #/m³</p>	<p>✓ Inside zone CO₂ Sensor</p> <p>600 ppm</p>	<p>✓ Inside zone Environment</p> <p>Relative Humidity 47.2% Temperature 30.2°C</p>	<p>✓ Outside zone PM_{0.5}</p> <p>6009183 #/m³</p>
<p>✓ Outside zone PM₁</p> <p>0.9 µg/m³ 6882656 #/m³</p>	<p>✓ Outside zone PM_{2.5}</p> <p>0.9 µg/m³ 6897778 #/m³</p>	<p>✓ Outside zone PM₄</p> <p>0.9 µg/m³ 6900153 #/m³</p>	<p>✓ Outside zone PM₁₀</p> <p>0.9 µg/m³ 6901553 #/m³</p>
<p>✓ Outside zone CO₂ Sensor</p> <p>604 ppm</p>	<p>✓ Outside zone Environment</p> <p>Relative Humidity 38.9% Temperature 34.4°C</p>		

ESGN_C_MA_K_00066_1

Live Charts

Live Charts allows the user to graphically chart any of the data recorded by OnGuard in any time period. Access this feature by clicking on Live Charts found under the Current Status heading.

Figure 72: Current Status Display

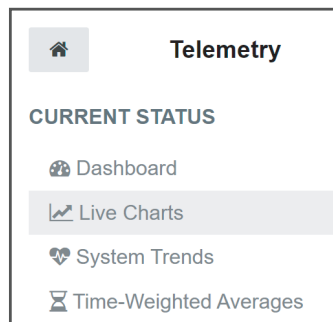

MAOG_A_MM_K_00042_1

Figure 73: Live Charts Graph Example

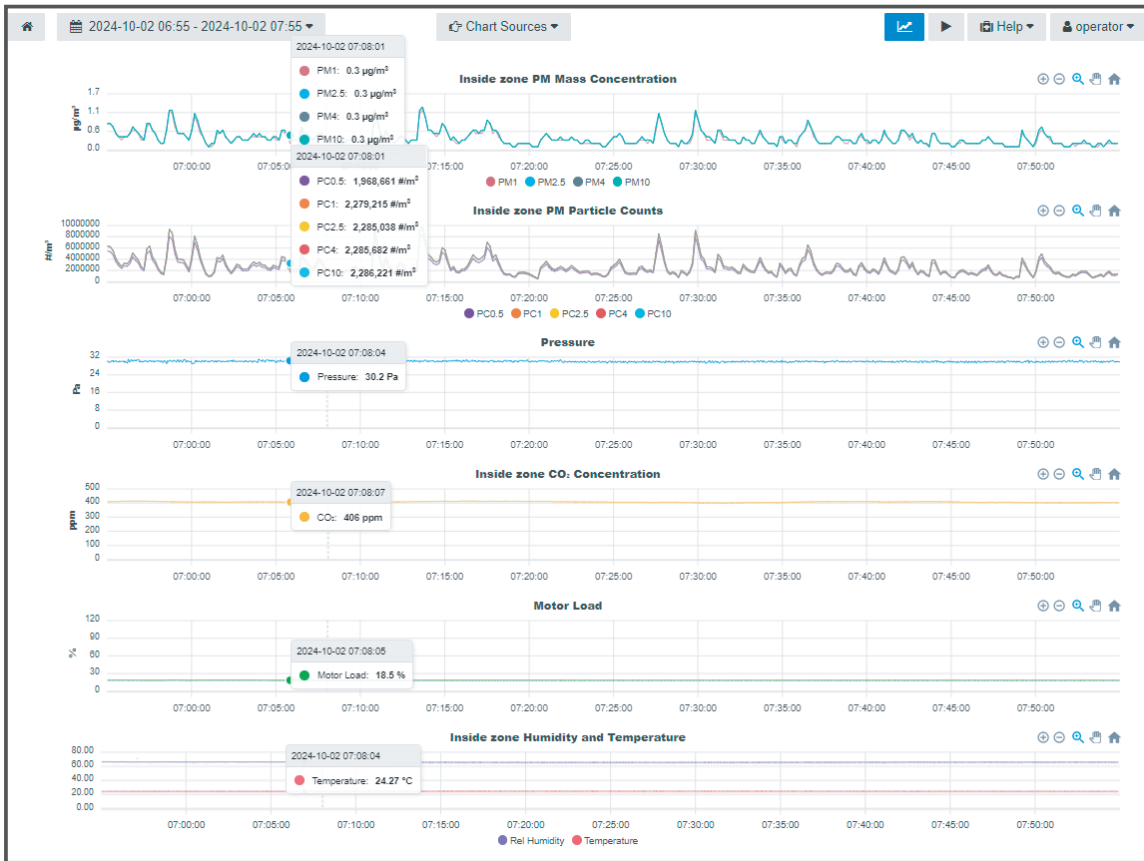

MAOG_A_MM_K_00041_1

The Live Charts default setting is to display:

- Pressure
- Motor Load
- Primary Sensor Pod Data (typically Breathing Zone)
- Particulate Matter (PM) Concentration
- PM Particle Counts
- Humidity and Temperature

To change the selection of data sources, hover over Chart Sources to see a pop-up menu with all available data sources.

If OnGuard is configured for multiple sensor zones, the Chart Sources menu will include options for each zone's sensor pods.

Once the preferred sources have been selected, click on the chart icon (top right) to refresh the charts display.

Figure 74: Chart Sources Display

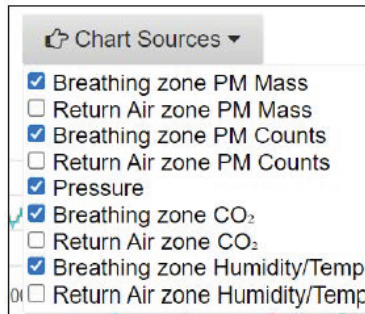

ESGN_C_MA_K_00058_1

Figure 75: Live Chart Selections



MAOG_A_MM_K_00034_1

01 - Chart Refresh Button

02 - Live Display Button

The period for which the data is charted can be selected using the date and time drop down on the top left of the page.

By default, the charts span the last hour, and the maximum chart period is two weeks.

Figure 76: Adjusting the Time Period of Charted Data

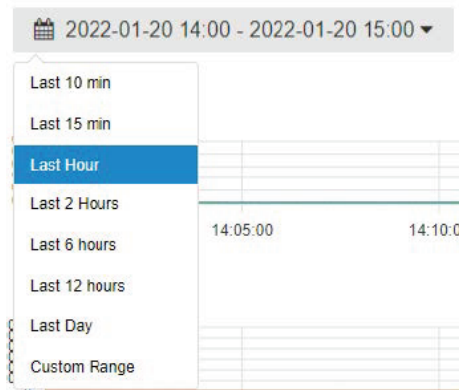

ESGN_C_MA_K_00059_1

In Live Display mode, the chart of the selected data sources is refreshed periodically to show the latest data as it is recorded. Live Display mode is available for chart periods up to and including the last 2 hours. Live Display can be toggled on and off using the gray play button and red stop button. See [Figure 75](#) on page 47.

Figure 77: Live Display Play and Stop Buttons



ESGN_C_MA_K_00050_1

Telemetry – Admin Only

The telemetry page allows an admin authenticated user to download data recorded by the unit in various formats:

1. Current Status
 - a. Dashboard (See [Live Dashboard](#) on page 44.)
 - b. Live Charts (See [Live Charts](#) on page 45.)
 - c. System Trends
 - d. Time-Weighted Averages
2. Complete Data
 - a. Complete SQLite Database: Downloads complete SQLite Database from all time.
 - b. Board, Accessory, and Customer Identifiers/Tags: Downloads historic identifier data in CSV format.
 - c. Alerts: Downloads historic alert data in CSV format.
 - d. Commands and Activities: Downloads historic commands and activity data in CSV format.

Complete Data downloads the latest recorded complete SQLite Database. This function will serve the most recent 1GB of data recorded.

3. Time Slots
 - a. Last Hour
 - b. Last Day
 - c. Last Week
 - d. Other Data Downloads

The rightmost section of the telemetry page allows the user to download data according to their category (particulate matter, pressure, etc.) in discrete time slots of the last hour, last day and last week of recorded data. For example, clicking Pressure and Motor Load under Last Day will download a .CSV file containing all recorded pressure and motor load data over the last 24 hours. Additionally, the user has the option to download all recorded in the last day, last week, last fortnight, or last month in SQLite Database format.

To log in as an admin, see [How to Access the Web Interface using the Wi-Fi Access Point](#) on page 44.

Figure 78: Telemetry: Admin Only

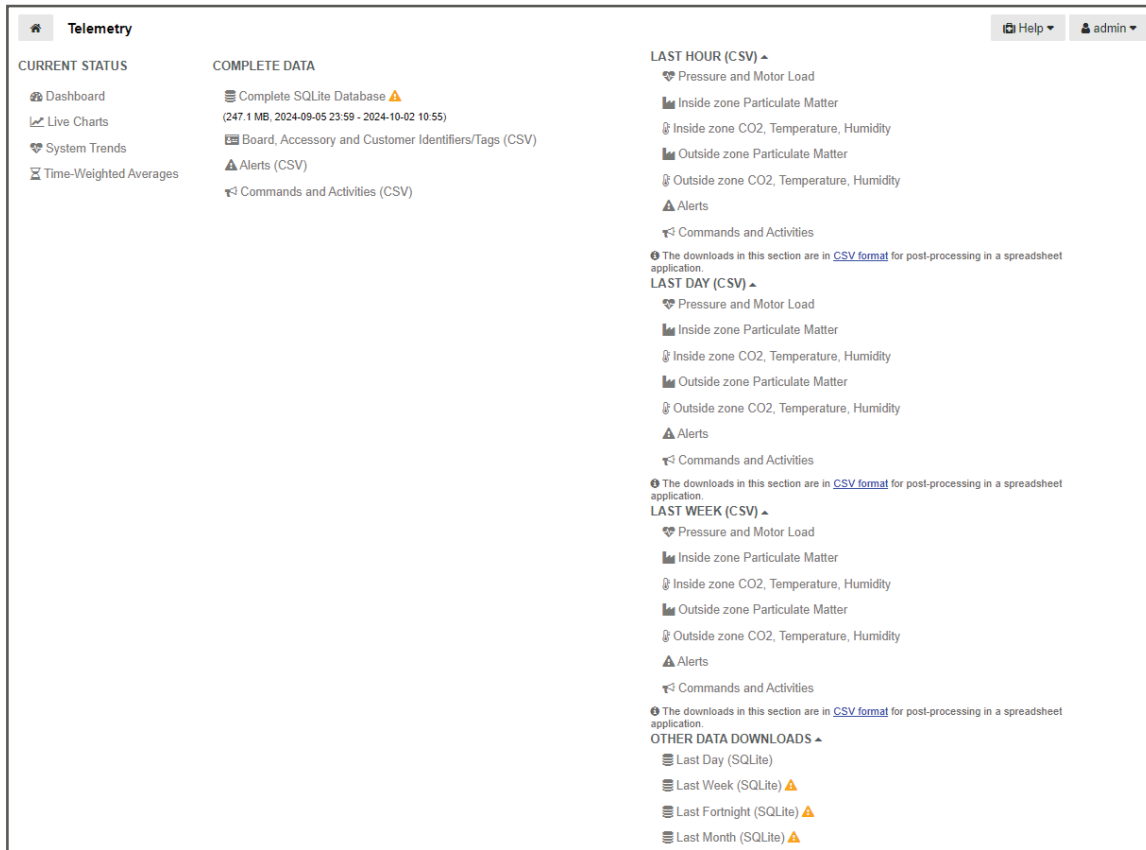

MAOG_A_MM_K_00038_1

Download Sensor Data

Before You Begin

The user must be logged into the Web Interface as an admin. See [How to Access the Web Interface using the Wi-Fi Access Point](#) on page 44.

Obtain the Info sheet for details about the Wi-Fi Access Point. See [System Description](#) on page 9.

A 2.4 GHz Wi-Fi capable device will be needed to access the Web Interface.

Individual data files showing sensor data can be downloaded and saved in Microsoft Excel format. The telemetry page allows an admin to download data recorded by the unit in various formats.

To download individual data files:

Step 1: Open a web browser.

It is recommended to complete the download in the operator’s cab.

Step 2: Click the Wi-Fi icon.

Figure 79: Wi-Fi Icon Location

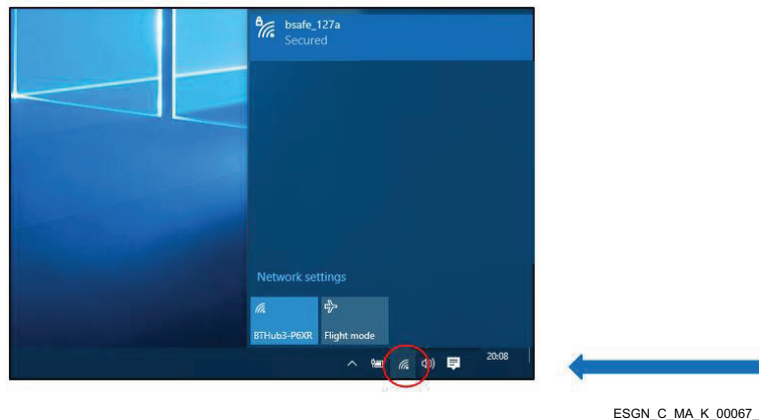

Step 3: Click Wi-Fi network being hosted by OnGuard.

This information can be found on the Info sheet.

These details are also shown in Net Config in the Admin menu. See [Network Configuration](#) on page 18. For OnGuard UI TS, see [Network Config](#) on page 36.

Step 4: Enter the password.

Figure 80: Wi-Fi Password Entry Prompt

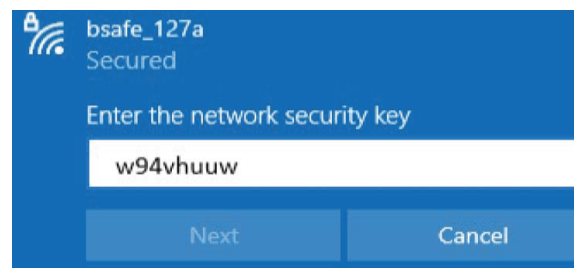

NOTICE

After the password is entered, the device will still show as not connected to Wi-Fi. This is a normal occurrence.

Step 5: Enter the IP address of the Wi-Fi AP into the address bar of the web browser.

The default IP address of all OnGuard kits is 192.168.7.1.

- Step 6:** Enter the admin username and password into the screen prompt.
This information can be found on the Info sheet.

Figure 81: Login Prompt

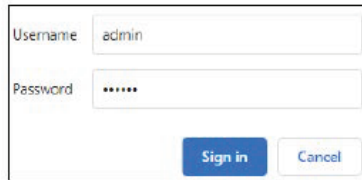

The image shows a login form with two input fields. The first field is labeled 'Username' and contains the text 'admin'. The second field is labeled 'Password' and contains six asterisks '*****'. Below the fields are two buttons: a blue 'Sign in' button and a white 'Cancel' button with a blue border.

ESGN_C_MA_K_00049_1

- Step 7:** Go to Telemetry.
See [Telemetry – Admin Only](#) on page 48.
- Step 8:** Select the individual file to be downloaded, with the historical choices of Last Hour, Last Day, or Last Week.
See [Telemetry – Admin Only](#) on page 48.
- Step 9:** Save the chosen file to a new or existing folder to be viewed later.
The file will be sent to the download folder on the device used.

Download SQLite Data

Before You Begin

The user must be logged into the Web Interface as an admin. See [How to Access the Web Interface using the Wi-Fi Access Point](#) on page 44.

Obtain the Info sheet for details about the Wi-Fi Access Point. See [System Description](#) on page 9.

A 2.4 GHz Wi-Fi capable device will be needed to access the Web Interface.

This describes how to download the Complete SQLite Data and individual data files that have been collected by the OnGuard system.

- Step 1:** Open a web browser.
It is recommended to complete the download in the cab.
- Step 2:** Click the Wi-Fi icon.

Figure 82: Wi-Fi Icon Location

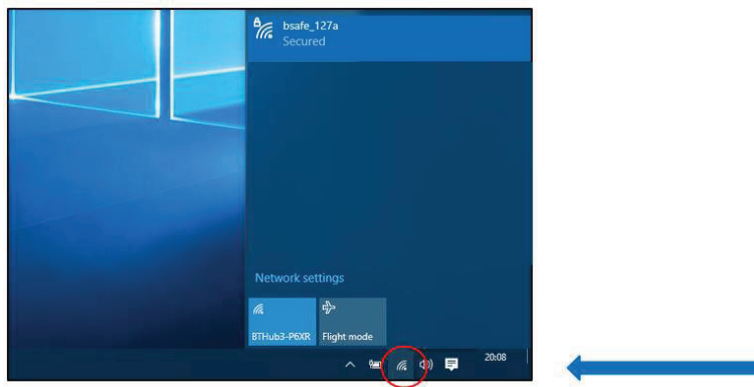

ESGN_C_MA_K_00067_1

Step 3: Click Wi-Fi network being hosted by OnGuard.

This information can be found on the Info sheet.

These details are also shown in Net Config in the Admin menu. See [Network Configuration](#) on page 18. For OnGuard UI TS, see [Network Config](#) on page 36.

Step 4: Enter the password.

Figure 83: Wi-Fi Password Entry Prompt

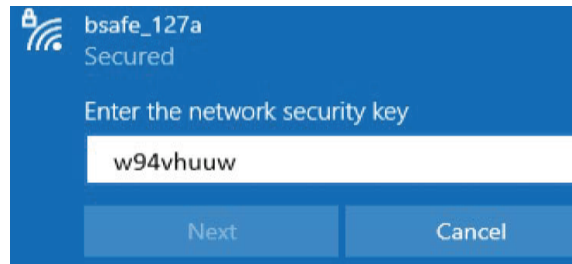

ESGN_C_MA_K_00053_1

NOTICE

After the password is entered, the device will still show as not connected to Wi-Fi. This is a normal occurrence.

Step 5: Enter the IP address of the Wi-Fi AP into the address bar of the web browser.

The default IP address of all OnGuard kits is 192.168.7.1.

Step 6: Enter the admin username and password into the screen prompt.

This information can be found on the Info sheet.

Figure 84: Login Prompt

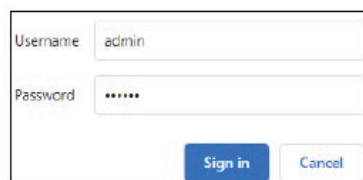

ESGN_C_MA_K_00049_1

Step 7: Go to Telemetry.

See [Telemetry – Admin Only](#) on page 48.

Step 8: Click on Complete SQLite Database under Complete Data to automatically download.

See [Telemetry – Admin Only](#) on page 48.

Do not move away from the screen until the download is complete. The download should take approximately 10 minutes. Once complete, the download will be saved to the downloads folder on the device.

To view the downloaded data, see [OnGuard Online Visualisation Tool](#) on page 53.

OnGuard Online Visualisation Tool

Before You Begin

The user must download the SQLite database files from the Web Interface. See [Download SQLite Data](#) on page 51.

A 2.4 GHz Wi-Fi capable device will be needed to access the Web Interface.

BreatheSafe hosts a free online service built for visualizing data downloaded from OnGuard units. This service allows anyone to upload SQLite database files downloaded from any OnGuard and visualize the uploaded data in the same format as the Live Charts page on the Web Interface. The user is provided with a unique page address for each uploaded database, allowing them to share the visualized data with anyone, anywhere.

To view the downloaded data using the online visualization tool:

Step 1: Reconnect to the local Wi-Fi or Ethernet network.

Step 2: Open a web browser.

Step 3: Type <https://view.breathe-safe.com/> into the address bar.

Step 4: Click on Choose File.

Figure 85: OnGuard Online Visualization 'Choose File'

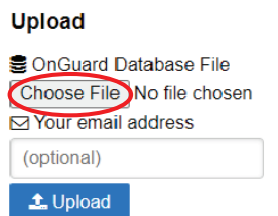

Upload

OnGuard Database File

Choose File No file chosen

Your email address

(optional)

Upload

ESGN_C_MA_K_00076_2

Step 5: Select the correct file from the downloads folder.

See [Figure 86](#) on page 54.

Step 6: Click Upload.

Figure 86: Upload File

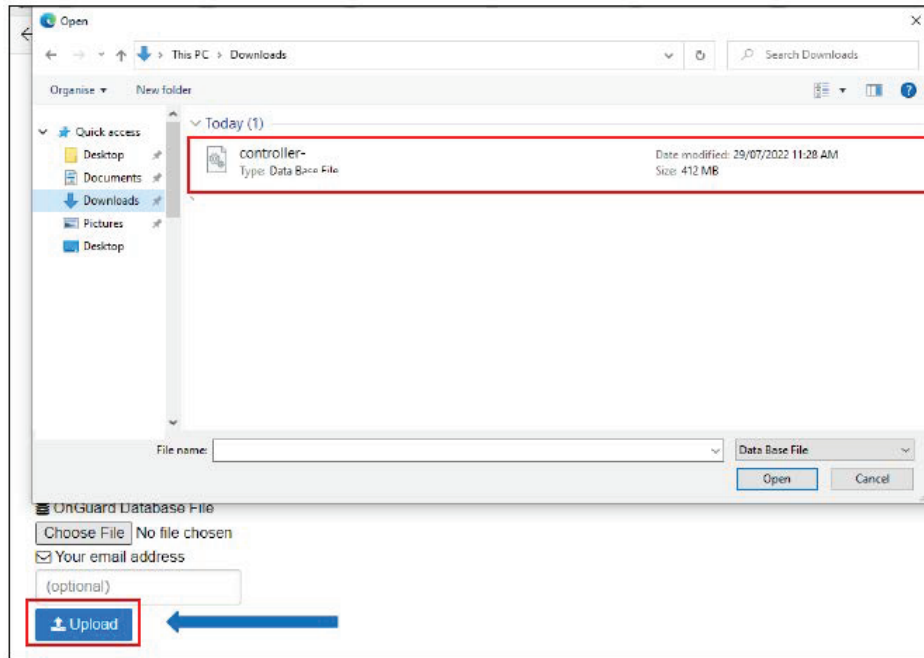

ESGN_C_MA_K_00062_1

NOTICE

Depending on your internet connectivity, this process may take a substantial amount of time.

The system will process the information and allow the downloaded data to be viewed.

Edit Configuration – Admin Only

CAUTION

Clicking Wipe and Factory Reset will permanently delete all data stored on the OnGuard unit. Be sure this action needs to be taken.

When logged in as admin, the user will be able to view and edit the OnGuard unit's current configuration, save the current or previous configurations externally by downloading them, or restore the unit to a previous configuration by clicking Restore next to the chosen configuration. Additionally, the user can wipe all recorded data from the unit and restore it to factory defaults by clicking Wipe and Factory Reset.

Figure 87: Web Interface Configurations

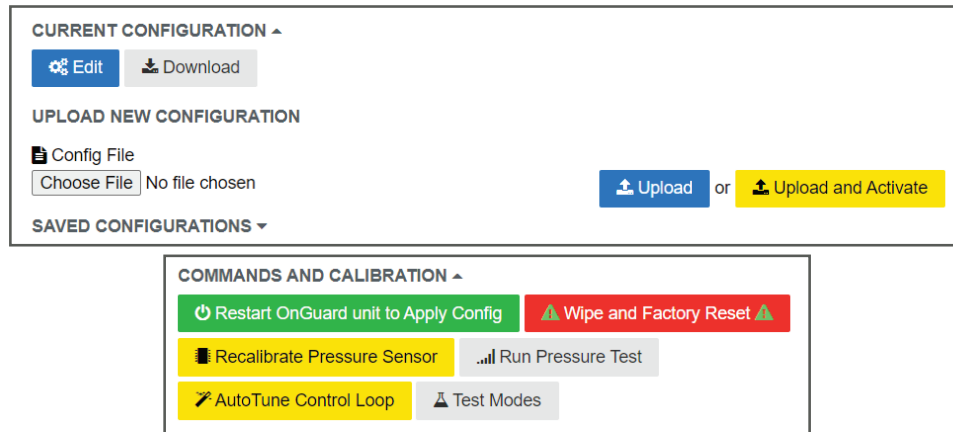

MAOG_A_MM_K_00035_1

Clicking on Edit under Current Configuration will allow the user to make changes to the unit's configuration. The available options are:

1. Connected Accessories: Rename, tag and/or reassign connect accessories (e.g. the sensors and UI)
2. Pressure Control: Adjust pressure set point.
3. Pressure Loss Alert: Adjust timing for pressure alarm.
4. CO₂ Sensors: Enable alert and adjust thresholds for sensor.
5. Particulate Matter Sensor: Enable alert and adjust thresholds for sensor.
6. Audible Alert Options: Adjust alert types and volume.
7. Access Control: Change Operator pin, Admin pin, and web API password.
8. Wi-Fi Embedded Access Point (AP): Configure the network name, password and other options for the AP hosted by OnGuard.
9. Wi-Fi, Client Mode: Configure the OnGuard to join an external Wi-Fi network.
10. Ethernet: Configure the OnGuard's connection to a network via Ethernet (must be plugged in already).

Hovering the cursor over any adjustable parameter in the configuration will bring up a description of the parameter being edited.

Figure 88: Hovering Cursor Over Parameter Example

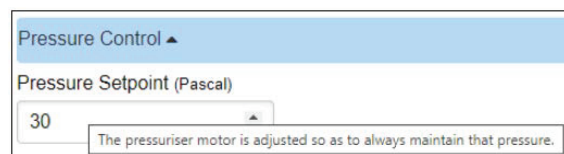

ESGN_C_MA_K_00042_1

How to use the Web Interface to Connect OnGuard to a Wi-Fi Network

Before You Begin

The Web Interface must be connected to the Wi-Fi AP and logged in as admin. See [How to Access the Web Interface using the Wi-Fi Access Point](#) on page 44.

Step 1: Click Edit under the Current Configuration heading.

Figure 89: Web Interface Configurations

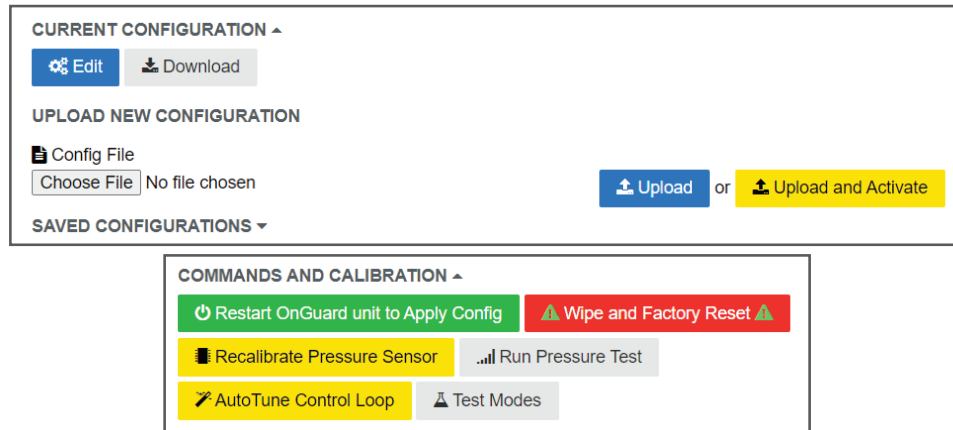

MAOG_A_MM_K_00035_1

Step 2: Scroll down to Wi-Fi, Client Mode.

Step 3: Enter the details of the network that OnGuard will connect to under Network Name and Password.

Figure 90: Wi-Fi, Client Mode Display



ESGN_C_MA_K_00054_1

Step 4: Click Save Changes.

Step 5: Click Restart OnGuard unit to Apply Config.
See [Figure 89](#) on page 56.

Step 6: Reconnect device to the Web Interface using the Wi-Fi AP.

Step 7: Navigate to Help → About

Figure 91: Help Menu

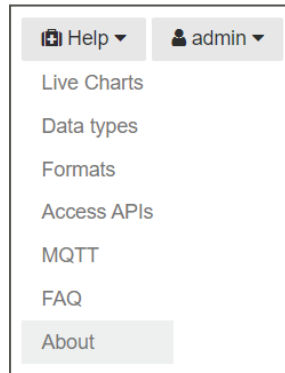

MAOG_A_MM_K_00036_1

Step 8: Verify OnGuard has successfully connected to the Wi-Fi network. Check that the Wi-Fi Client is Up and has an IP Address assigned. If the status of the Wi-Fi Client is Down, manually restart the Main Unit by powering it off and then powering it back on after 10 seconds.

Figure 92: Network Connections

	Connection Type	Status	IP Address
Network Connections	WiFi Access Point	Down	
	WiFi Client	Up	
	Wired Ethernet	Up	149.28.173.70
	Remote Access VPN	Enabled but Down	

MAOG_A_MM_K_00037_1

The Web Interface can now be accessed on this network by navigating to the IP address displayed next to Wi-Fi Client on any web browser.

If this process was unsuccessful, see [Web Interface Wi-Fi Network Connection Troubleshoot](#) on page 57.

Web Interface Wi-Fi Network Connection Troubleshoot

Use the steps below to troubleshoot a failure to connect to a Wi-Fi Network using the Web Interface.

If the network status shows that the Wi-Fi Client is Down, then OnGuard has not successfully connected to the network. See [Step 8](#) on page 57.

- Step 1:** Verify that all network details were entered correctly.
See [Step 3](#) on page 56.
- Step 2:** Verify that the desired Wi-Fi network is booted.
- Step 3:** Restart OnGuard by powering off the Main Unit for 10 seconds.
- Step 4:** Verify the Wi-Fi Client is Up.
See [Step 8](#) on page 57.

Connecting with Ethernet

Before You Begin

The device must have administrative access to complete this process.

The device must have an ethernet port.

The Web Interface can be accessed using the ethernet port located on the front of the Main Unit.

Step 1: Connect one end of an ethernet cable to the device's ethernet port.

Step 2: Connect the other end of the ethernet cable to the Main Unit's center front port.

NOTICE

Older versions of the Main Unit may not include the access plug shown in the graphic below.

To access the center front port on older versions:

- 1. Remove the face plate screws.*
- 2. Remove the unit's face plate.*
- 3. Remove the access cover.*

Figure 93: OnGuard Main Unit Center Front Port

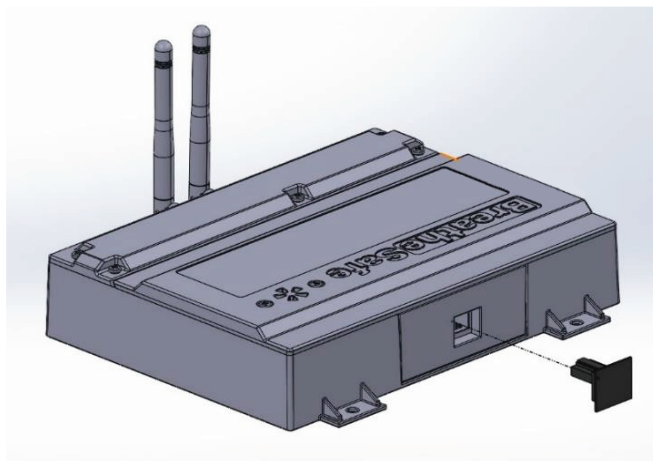

ESGN_C_MA_K_00088_1

Step 3: Go to network settings on the device.

Step 4: Click on the Unidentified network.

Figure 94: Wi-Fi Pop-up Window

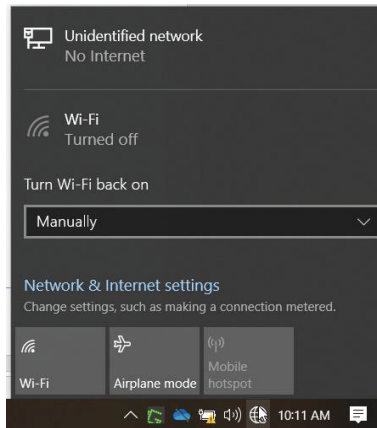

ESGN_C_MA_K_00078_1

Step 5: Click on Change adapter options located under Related Settings.

Figure 95: Ethernet Settings Window

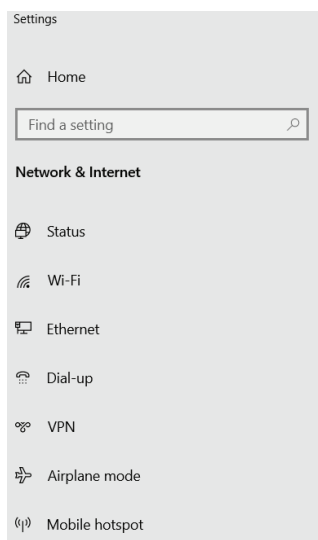

— □ ×

ESGN_C_MA_K_00079_1

Step 6: Right click on the Ethernet icon.

Step 7: Click on Properties.

Figure 96: Network Connections Window

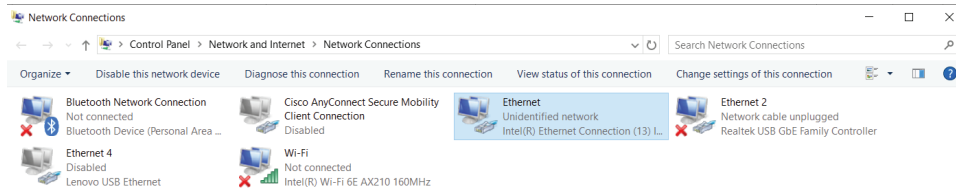

ESGN_C_MA_K_00080_1

Step 8: Enter the administrative access credentials in the pop-up window.

Figure 97: Access Credentials Entry Window

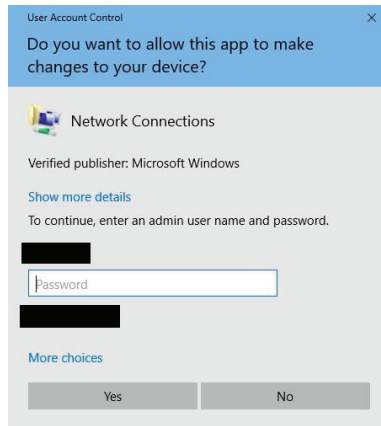

ESGN_C_MA_K_00081_1

Step 9: Click on Internet Protocol Version 4 (TCP/IPv4).

Step 10: Click on Properties.

Figure 98: Ethernet Properties Window

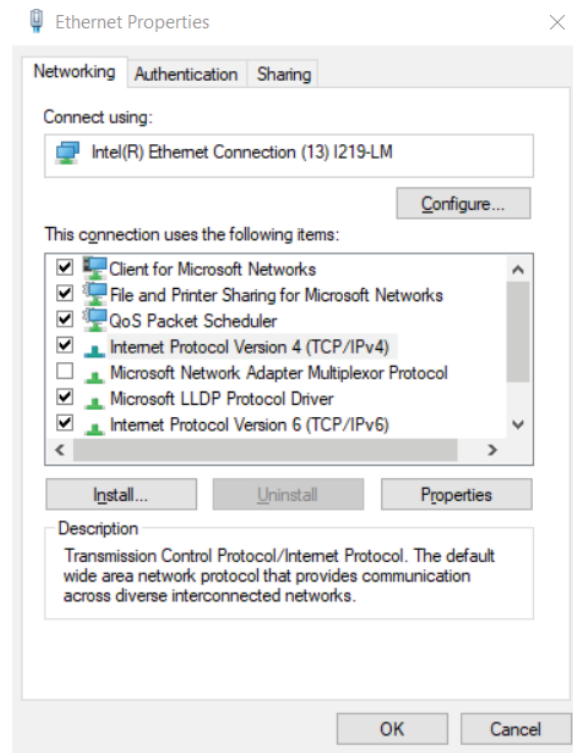

ESGN_C_MA_K_00082_1

Step 11: Enter **192.168.1.42** for the IP address.

Step 12: Enter **255.255.255.0** for the Subnet mask.

Step 13: Click on OK.

Figure 99: 'Internet Protocol Version 4 (TCP/IPv4)' Properties Window

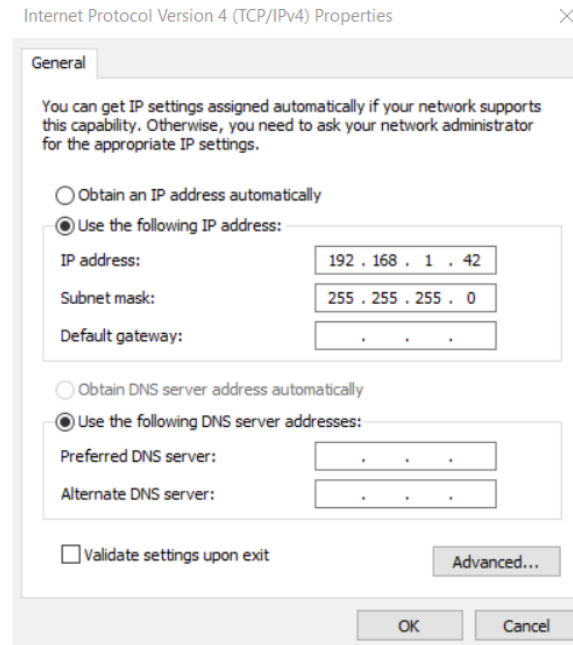

ESGN_C_MA_K_00083_1

Step 14: Go back to the Network Connections window.

Step 15: Right click on the Ethernet icon.

Step 16: Click on Status.

Figure 100: 'Status' Location in Network Connections Window

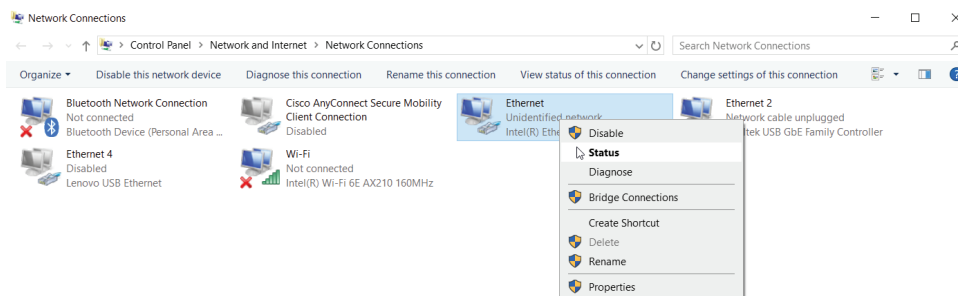

ESGN_C_MA_K_00084_1

Step 17: Confirm that **192.168.1.42** is in the IPv4 Address line.

Step 18: Click on Close.

This has assigned the device being used the IP address to be able to communicate with the Main Unit.

Step 19: Open a web browser.

Step 20: Enter **192.168.1.40** into the address bar.

Step 21: Confirm that this is the correct IP address.

This information is listed on the Info sheet. See [System Description](#) on page 9.

The Web Interface will now be visible on the web browser being used.

Figure 101: Web Interface

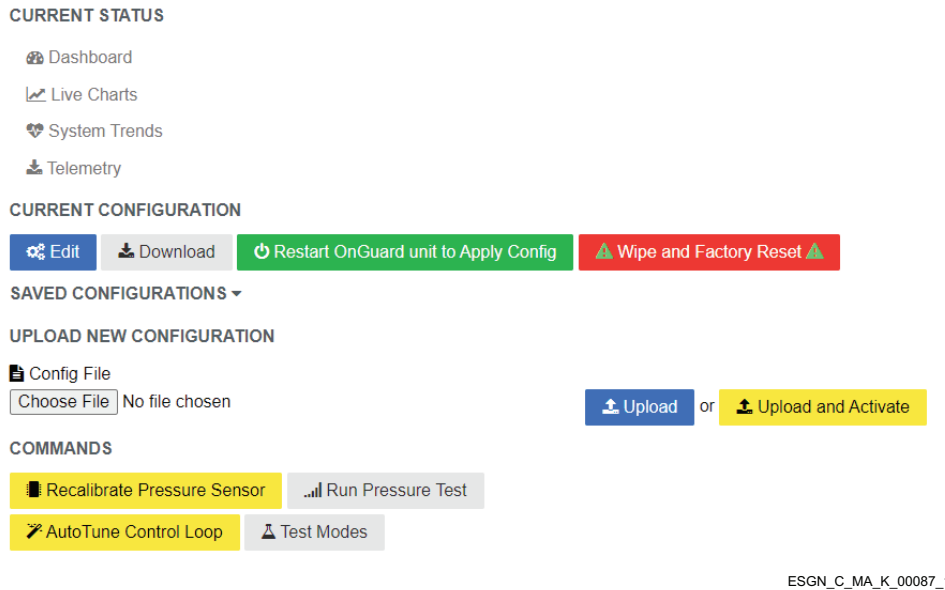

Data Types and Measurement Details

Navigating to Help → Data Types will provide the user with a detailed description of every data type collected by the OnGuard. This page is especially helpful if downloading data in .CSV format, as it will help the user find the identifier used for every data type and the description used.

Figure 102: Help Menu

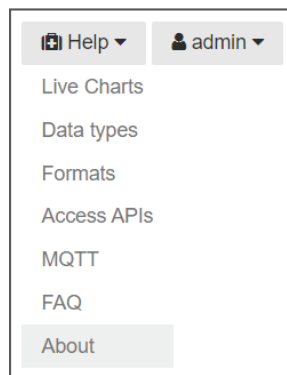

MAOG_A_MM_K_00036_1

About

Navigating to Help → About will provide the user with information specific to OnGuard’s hardware and configuration. This page can assist in the post-installation and initial start-up of an OnGuard, as it lets the user verify that all expected peripherals are connected properly and are reporting data to OnGuard.

Figure 103: Help Menu

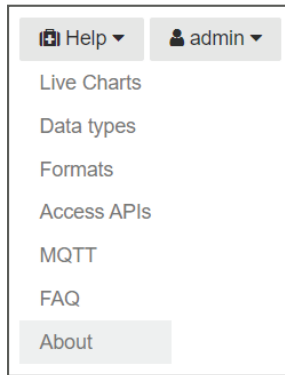

MAOG_A_MM_K_00036_1

Figure 104: About

About this OnGuard Unit

OnGuard Main Unit Serial Nr.	1234567			
OnGuard Hardware Type	DEMODEMO-BWA5-8-9			
Software Release	Demo Release (released at 2024-01-01 00:00:00)			
Configured Options	Pressuriser Control, Display, CO ₂ and PM Sensors, 2 Sensor Zones			
Vehicle/Installation Type	this is a demo.			
Vehicle/Installation ID	vehid			
Vehicle/Installation Serial Nr.	Not Set			
Network Connections	Connection Type	Status	IP Address	
	WiFi Access Point	Down		
	WiFi Client	Down		
	Wired Ethernet	Up	149.28.173.70	
	Remote Access VPN	Enabled but Down		
Connected Accessories	Type	Serial Nr.	ID Tag	Zone Assignment
	CO ₂ /PM Sensor	2021	ontop	Outside zone
	CO ₂ /PM Sensor	3456	dangling	Inside zone
	Display Pod	9876		N/A

MAOG_A_MM_K_00040_1

Components

OnGuard Interface Module

The OnGuard Interface Module (Main Unit) is a device that monitors the cabin air pressure. The module also controls the Pressurizer Motor speed in response to conditions in the operator's cabin. These conditions include CO₂, dust, and pressure. This module can transmit a Wi-Fi signal, and continuously record and store its data. The data can be accessed from either an ethernet connection or Wi-Fi.

Figure 105: OnGuard Interface Module



ESGN_C_MA_K_00073_1

Sensor Pod

The sensor pod mounted on the inside of the cabin and are used to measure:

- Dust particulate matter count
- Dust particulate matter mass concentration
- CO₂ concentration

This information is then relayed back to the main unit.

A coarse filter is used to remove non-respirable particles from the air before it reaches the sensors, prolonging the life of the unit and improving its accuracy in measuring respirable particles.

OnGuard has the option of having two sensor pod types:

1. Breathing Zone Sensor Pod
2. Return Air Sensor Pod (Optional)

The breathing zone sensor pod is mounted within the breathing zone of the operator. The return air sensor pod is mounted near the air duct at the base of the cab.

Figure 106: Sensor Pod

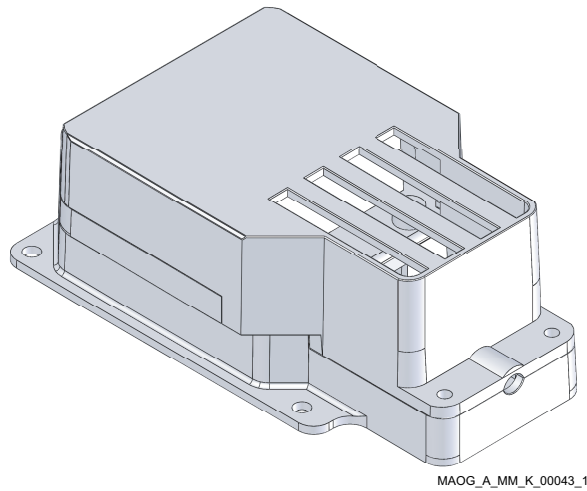

MAOG_A_MM_K_00043_1

How to Replace a Sensor Pod

NOTICE

For recommended inspection intervals and maintenance schedules, refer to the Preventive Maintenance Plans Manual or your Life Cycle Management program plan.

To replace a Sensor Pod:

- Step 1:** Turn off the power for the OnGuard Main Unit.
- Step 2:** Remove the four mounting bolts in each corner of the sensor.
- Step 3:** Remove the four screws from the top of the sensor, then remove its lid.
Do this same procedure for the new sensor pod.

Figure 107: Sensor Hole Locations

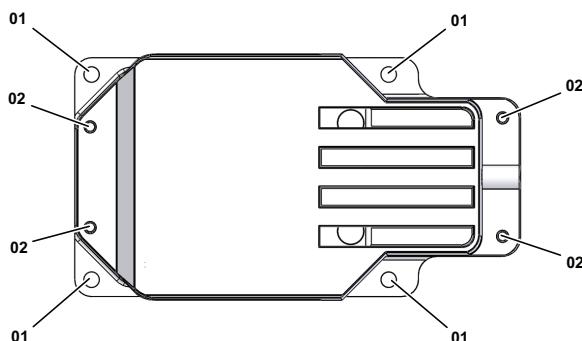

ESGN_C_MA_K_00089_2

01 - Mounting Bolt Holes**02 - Lid Screw Holes**

- Step 4:** Unplug the RJ45 cable from the old sensor pod.
Replace the RJ45 cable if there are any visible signs of damage to the cable or to the plug.
- Step 5:** Connect the RJ45 cable to the new sensor pod.
- Step 6:** Reinstall the lid to the sensor.
- Step 7:** Reinstall the four screws that hold the lid in place.
Special care must be taken to ensure the 4 colored wires inside the case are not clamped by the lid when putting it back on the case.
Do not over tighten the screws as excessive force will strip the threads inside the plastic.
- Step 8:** Re-mount the sensor and reinstall the four mounting screws.
- Step 9:** Power on the OnGuard Main Unit.
- Step 10:** Sign in to the Web Interface as an admin.
- Step 11:** Click edit under the Current Configuration heading.

Figure 108: Current Configuration Display

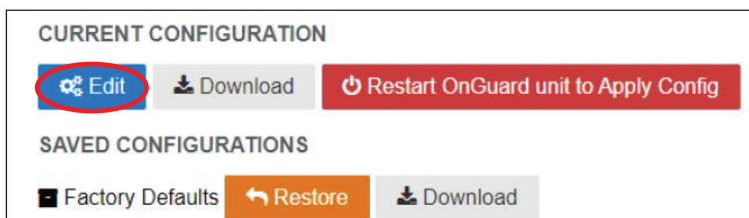

ESGN_C_MA_K_00031_1

Step 12: Scroll down to the Connect Accessories heading.

Figure 109: Connect Accessories Display

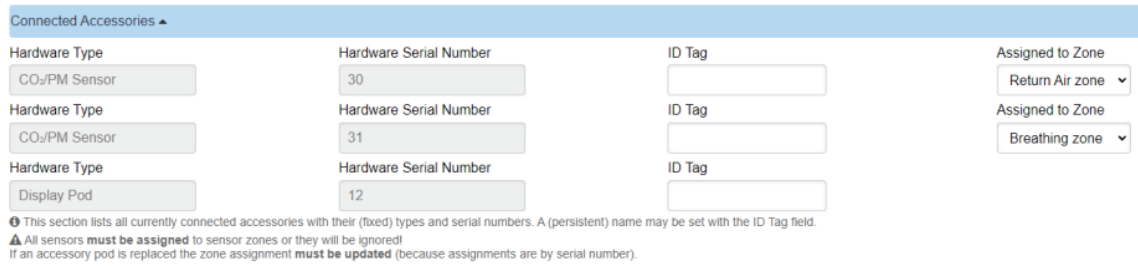

ESGN_C_MA_K_00091_1

Step 13: Verify the newly replaced sensor has successfully connected to the OnGuard system.

Make sure the number under Hardware Serial Number matches the serial number on the sticker attached to the new sensor.

Figure 110: Serial Number Verification



ESGN_C_MA_K_00092_1

Step 14: Click this drop-down menu and select a zone.

Assigned to Zone will display as None. This should be the same zone that applied to the old sensor.

Figure 111: Assigned to Zone Selection

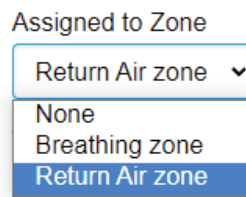

ESGN_C_MA_K_00093_1

Variable Speed Pressurizer

The Variable Speed Pressurizer automatically adjusts its speed in response to conditions within the cab. The pressurizer also includes a HEPA14 Fresh Air Filter to filter incoming air, which mounts directly onto the end of the pressurizer.

Figure 112: Variable Speed Pressurizer



MAOG_A_MM_K_00044_1

Variable Speed Pressurizer Air Filter Replacement

NOTICE

For recommended inspection intervals and maintenance schedules, refer to the Preventive Maintenance Plans Manual or your Life Cycle Management program plan.

CAUTION

Air filters must not be cleaned or reused and must be disposed of. Replace the old air filter with a new air filter based on your recommended service interval and maintenance schedule. Not completing this properly may cause premature failure of the Variable Speed Pressurizer.

To replace the Pressurizer Air Filter:

- Step 1:** Turn off and isolate the power to the pressurizer and HVAC unit.
- Step 2:** Inspect the pressurizer for any damage.
- Step 3:** Lift the locking tab located on the side of the filter housing.
- Step 4:** Turn the filter counterclockwise and remove the filter from the pressurizer.
- Step 5:** Inspect the inside of the housing and sealing surface for any dirt/debris. Clean if dirt/debris is found.
- Step 6:** Install the new filter.
- Step 7:** Rotate the filter clockwise until the locking tab locks into place.

Figure 113: Pressurizer Air Filter



ESGN_C_MA_K_00069_1

Variable Speed Pressurizer Replacement

NOTICE

For recommended inspection intervals and maintenance schedules, refer to the Preventive Maintenance Plans Manual or your Life Cycle Management program plan.

- Step 1:** Turn off and disconnect power to the pressurizer.
- Step 2:** Disconnect the pressurizer's 3-Pin Deutsch connector.
- Step 3:** Disconnect hose clamps and remove pressurizer tubing as necessary.
The tube routing may be different depending on the machine the pressurizer is installed on.
- Step 4:** Remove the rain cover from the top of the pressurizer.
- Step 5:** Remove the pressurizer's bottom mounting bolts.
- Step 6:** Remove old pressurizer.
- Step 7:** Install the new pressurizer.
- Step 8:** Bolt pressurizer down using the bottom mounting bolts.
- Step 9:** Reinstall pressurizer rain cover.
- Step 10:** Reconnect any tubing and hose clamps.
- Step 11:** Reconnect the pressurizer's 3-Pin Deutsch connector.
- Step 12:** Reconnect and turn on power to the pressurizer.

Clean Cab Variable Pressurizer Motor Control

NOTICE

Site conditions may alter when an inspection is necessary. For recommended inspection intervals and maintenance schedules, refer to the Life Cycle Management program plan.

The OnGuard Active Unit is equipped with clean cab variable motor control. This allows the pressurizer to introduce controlled volumes of air to maintain setpoint ideal pressure. The motor capacity indicator on the OnGuard UI TS home screen will show in real-time and alert the user when it is time to change the filter. The percentage shown next to *Motor* is how hard the motor has to run to keep its assigned pressure. If the percentage is between 10% and 80%, the filter is serviceable. If the percentage is over 80%, it is recommended to change the filter. See [Variable Speed Pressurizer Air Filter Replacement](#) on page 69. A green status will be shown until the motor is unable to keep up.

The clean cab control also monitors CO₂ levels using standard setpoints. If the levels reach 1000 PPM or 500 PPM over ambient level (varies per site location), the pressurizer motor will increase its output to flush out the cabin. The alarm will sound after two minutes if the level does not drop below 1000 PPM or 500 PPM over ambient level (varies per site location). These settings can be changed through the OnGuard UI TS. If an alarm is experienced, manual intervention is recommended to determine the source of high levels of CO₂.

Figure 114: Motor Capacity Indicator

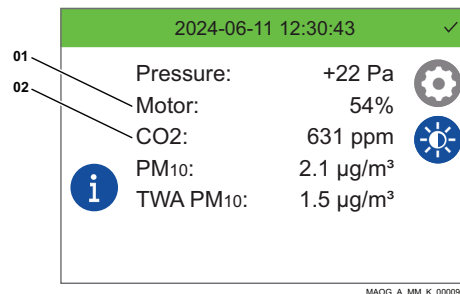

01 - Motor Capacity Indicator

02 - CO₂ Level

This Page Intentionally Left Blank

Maintenance

NOTICE

Site conditions may alter when an inspection is necessary. For recommended inspection intervals and maintenance schedules, refer to the Life Cycle Management program plan.

Table 2: 500 Hour Inspection

Component/System	Action
Pre-cleaner	Verify that the pre-cleaner is clean and operational.
Pressurizer Motor	Verify that the motor is operational.
Primary HEPA Filter	For OnGuard Generic Unit: <ul style="list-style-type: none"> Replace HEPA filter element. Clean housing before replacing the filter elements.
	For OnGuard Active Unit: <ul style="list-style-type: none"> Inspect filter motor capacity indicator on the TS UI. Replace HEPA filter if the fan capacity indicator states 80% or greater. Clean housing before replacing the filter elements.
Return HEPA Air Filter (Varies depending on cab)	<ul style="list-style-type: none"> Inspect filter Vacuum the cabin floor before replacing filter.
Filter Frame Assembly, Mounts, Cab Seals and Filter Housing	<ul style="list-style-type: none"> Check door seals and cab integrity Check that all bolts, screws, and mounts are secure. Check the filter canister. Ensure it is correctly fitted. Check that all latches are operational. Replace or re-tension fixtures and fittings.

Table 3: 15,000 Hour/ 36 Month Inspection

Component/System	Action
500 Hour Inspection	Perform 500 hour inspection.
Pressurizer Motor	For OnGuard Generic Unit: <ul style="list-style-type: none"> Replace brushless pressurizer motor.
	For OnGuard Active Unit: <ul style="list-style-type: none"> Replace brushless pressurizer motor or complete assembly.

This Page Intentionally Left Blank

Troubleshooting

Controller Display Screen Messages

Table 4: Display Screen Messages

Alert Type	Display Screen Message (UI)	Display Screen Message (UI TS)	Problem	Possible Solution
Notification: System Start	STARTING UP...	STARTING UP...	None. System is starting up.	N/A
Notification: System start delay	STARTING UP... AWAITING PRESS.	Starting Up... Awaiting Pressure...	System has not detected cabin pressure and is waiting to detect pressure before starting pressure test. Factory set wait time is 30 seconds.	Close door and windows. Check if pressure tube running outside cabin is connected to unit's ambient pressure fitting (Pipe A).
Notification: System restarting	RESTARTING	RESTARTING	None. This is normal when system has been commanded to restart.	N/A
Notification: System shut down	SHUTTING DOWN	Shutting Down...	None. This is normal when system is re-booted.	N/A
Notification: Automatic pressure test	PRESSURE TEST	PRESSURE TEST	None. System is running a pressure test to determine how much pressure can be attained in the cab. Pressure target is factory set at 250 Pa	N/A
Notification: Pressure test did not reach target	PRESSURE TEST FAILED TRGT NOT REACHED	Low Test Pressure Target Pressure not reached	System did not achieve test pressure (default 250 Pa).	Enclosure sealing and filter need be checked during next scheduled maintenance interval.
Command Received: Fixed speed	MAX SPEED TEST	MAX SPEED TEST	None. System has been commanded to run at maximum speed to check maximum achievable cabin pressure. Cancel fixed speed operation by pressing middle button on display.	N/A

Alert Type	Display Screen Message (UI)	Display Screen Message (UI TS)	Problem	Possible Solution
Command Received: Pressure sensor recalibration	CALIBRATING... SWITCH A/C OFF OPEN DOOR/ WINDOW	CALIBRATING... SWITCH A/C OFF OPEN DOOR/ WINDOW	None. System has been commanded to rezero the differential pressure sensor. Make sure the cabin door is open. Ambient and positive fittings need to be exposed to the same pressure. Use a short loop of tubing to connect pressure fittings together to ensure this.	N/A
Notification: Pressure sensor recalibration complete	CALIBR. DONE CLOSE DOOR/ WINDOW	Calibration completed Close Doors and Windows	None. The differential pressure sensor calibration is complete. Close doors and windows.	N/A
Command Received: Pressure control autotune function	AUTOTUNING	AUTOTUNING	None. Will only be seen if instructed by the factory to run an Autotune cycle. Autotuning is an advanced feature that is only needed in special circumstances. Doors and windows must remain fully closed for entire duration of the Autotune operation.	N/A
Warning: Autotune failure	AUTOTUNE FAILED	AUTOTUNE FAILED	None. Unit will revert to original pressure control parameters. If Autotune operation is repeated, ensure doors and windows are closed.	N/A
Warning: Motor overload alert	OVERLOAD! PRESSURE TOO LOW CHECK FILTER!	Max Capacity Pressure is low, Check Filter!	Motor is consistently operating at 100% speed and cannot reach target pressure. Setpoint is factory set to 50 Pa.	Ensure cab is sealed. Check ducting to pressurizer and filter condition. Replace filter if issue persists.
Warning: Pressure loss	PRESSURE WARNING CLOSE DOOR/ WIND	Pressure Warning Close Doors and Windows	Pressure has dropped below warning threshold. The unit will stay at a fixed speed until pressure is detected. Warning will escalate to alarm level if pressure does not return. Factory settings: pressure warning 5 Pa, fault speed 30%, alarm delay 2 minutes.	Ensure cab is sealed. Check if outside pressure tube is connected to the outside port. Make sure it is not kinked or blocked.

Alert Type	Display Screen Message (UI)	Display Screen Message (UI TS)	Problem	Possible Solution
Alarm: No pressure (See Notice .)	NO AIR PRESSURE CLOSE DOOR/ WIND	No Air Pressure Check Doors and Windows!	Pressure loss warning has persisted for longer than 2 minutes (factory setting) and unit has escalated the warning to an alarm.	Ensure cab is sealed. Check if outside pressure tube is connected to unit and not kinked or blocked. Check pressurizer is powered and running. Check ducting from pressurizer to cab.
Warning: High CO ₂ level	HIGH CO ₂ LEVEL	HIGH CO ₂ LEVEL	First alert threshold for CO ₂ level reached. Factory setting 1000 ppm.	Ensure A/C is running on 1/2 speed or higher. Do not breath on sensor pod.
Alarm: Very high CO ₂ level	VERY HIGH CO ₂ LEVEL	VERY HIGH CO ₂ LEVEL	Second alert threshold for CO ₂ level reached. Factory setting 2500 ppm.	Ensure A/C is running on 1/2 speed or higher. Do not breath on sensor pod. Ensure sensor pod is located where air is being circulated effectively by cabin HVAC system.
Alarm: High dust level	HIGH DUST LEVEL	HIGH DUST LEVEL	Alarm state. Dust is entering the cab.	Check doors and windows, and close. Check if pressurizer filter is correctly installed.
Alarm: Sensor not detected	NO PM SENSOR CHECK POD CABLE	NO PM SENSOR CHECK POD CABLE	Unit failed to detect sensor pod.	Check sensor pod cable is securely connected (locked into connector) to unit and the sensor pod. Restart unit. Replace sensor pod if alert persists.
Alarm: Sensor not detected	NO CO ₂ SENSOR CHECK POD CABLE	NO CO ₂ SENSOR CHECK POD CABLE	Unit failed to detect sensor pod.	Check sensor pod cable is securely connected (locked into connector) to unit and the sensor pod. Restart unit. Replace sensor pod if alert persists.
Alarm: Sensor fault	PM SENSOR FAULT	PM SENSOR FAULT	Unit has detected a sensor pod fault.	Ensure airflow to sensor pod is not blocked or obstructed. Replace sensor pod if alert persists.
Notification: System identifier not set	CFG INCOMPLETE Set Vhicle ID, Ser#, or Tag	CFG INCOMPLETE! Set Vhicle ID, Ser# or Tag	No system identifier or tag has been set in the units configuration.	Log into the unit's web interface and save vehicle ID, serial number, or type to configuration.
Warning: Sensor pipe swap detection	P/PIPES SWAPPED	P/pipes swapped	Unit has detected pressure reference tube connected to the incorrect port.	Ensure pressure tube running outside the cabin is connected to 'Pipe A' (left fitting).

Alert Type	Display Screen Message (UI)	Display Screen Message (UI TS)	Problem	Possible Solution
Alert: Barometer sensor fault	NO BARO SENSOR	No Barometric Sensor CO ₂ may be under-reported!	Unit has detected a barometer sensor fault.	Restart unit. Replace if problem persists.
Alarm: Hardware failure	SYSTEM FAULT NO PRESSURE DATA	SYSTEM FAULT NO PRESSURE DATA	Unit has detected a hardware fault.	Restart unit. Replace if problem persists.

NOTICE

If the operator notices continuous cab pressure alarms, this can normally be corrected by changing the pressurizer filter. Over time, however, continuous cabin pressure alarms can also be attributed to the following:

- *HVAC unit fan failure*
- *Pressurizer motor failure*
- *Worn cab door seals or other seals*
- *Dirty return air filters*

Index

A

About	
OnGuard system	
web interface	63
Access	
operator and admin menus	29
Access pin	
user interface	14
Action menu	
user interface	14
TS	28
Adjust	
setpoint	
OnGuard UI TS	32
Admin menu	
user interface	18
Alerts	26
admin menu	
user interface	21
history	31
options	38
AutoTune	
admin menu	
user interface	20
control	
OnGuard UI TS	35

B

Buzzer adjustment	
admin menu	
user interface	22

C

Calibrate	
pressure sensor	32
Clean cab control	
variable speed pressurizer	71
Components	65
Configuration	
edit	
admin only	54
Connection	
network	43
web interface	43
Copyright.....	3

D

Data sources	
live charts	45

Date and time operation menu	15
F	
Factory reset admin menu user interface	23
Filter replacement pressurizer.....	69
I	
Interface module OnGuard system	65
L	
Live dashboard web interface	44
M	
Maintenance	73
Maximum speed test user interface	14
Menu admin OnGuard UI TS	34
operator OnGuard UI TS	32
N	
Network config OnGuard UI TS	36
status OnGuard UI TS	33
Network configuration admin menu user interface	18
Network status user interface	17
O	
OnGuard active unit	25
generic unit.....	11
OnGuard UI TS dashboard	27
home screen.....	25
screen brightness.....	27

Operation menu	
admin access	
user interface	22
user interface	15
P	
Preface.....	3
Pressure sensor calibration	
user interface	16
Pressure test	
admin menu	
user interface	21
Pressurizer	68
R	
Replacement	
pressurizer.....	70
Reset	
factory	
OnGuard UI TS	39
Revision record	7
S	
Safety hazard indicators	4
Sensor data	
download.....	49
Sensor pod	65
replacement.....	66
Set	
time and date	34
Setpoint	
user interface	16
SQLite data	
download.....	51
visualization tool.....	53
System description	
pressurization and onguard monitoring system	9
T	
Test	
full speed	31
pressure	
OnGuard UI TS	38
Troubleshoot.....	75
controller display screen messages	
user interface	75
Types and details	
data and measurement	
web interface	63

U

User interface	
controller display	13
OnGuard	11
TS	25
operator and admin menu	
access	14

W

Web interface	43
connect to a Wi-Fi network	56
ethernet connection	58
telemetry	
admin only	48
troubleshoot	
Wi-Fi network connection	57
using the Wi-Fi access point	44

OnGuard System -

Form No. MAOG-A-V-MM-EN-0001

© 2025 Komatsu Ltd. or one of its subsidiaries.
All rights reserved.
